

# USER MANUAL

## **TCOMSYS01 Hot Cube**

Thermal comfort measuring system



## Warning statements



Putting a voltage of over 30 VDC to TCOMSYS01 may result in permanent damage to the system.



TCOMSYS01 has an internal battery in the MCU that powers the clock and the SRAM when external power is not supplied. If the battery is exhausted, contact the factory for instructions.



Connect both cables to the TCOM01 sensor body and the MCU before turning on the MCU.



TCOM01 contains a resettable temperature fuse, which limits use to 60 °C.

# Contents

<b>Warning statements</b>	<b>2</b>
<b>Contents</b>	<b>3</b>
<b>Introduction</b>	<b>4</b>
<b>1 Ordering and checking at delivery</b>	<b>11</b>
1.1 Ordering TCOMSYS01	11
1.2 Included items	11
<b>2 Instrument principle and theory</b>	<b>13</b>
2.1 MCU Measurement and Control Unit	13
2.2 TCOM01 sensor body	14
<b>3 Specifications of TCOMSYS01 Hot Cube</b>	<b>16</b>
3.1 Dimensions of TCOMSYS01	19
<b>4 General directions for performing a measurement of thermal comfort</b>	<b>20</b>
<b>5 Installation</b>	<b>21</b>
5.1 Electrical connection	21
5.2 Mechanical setup	22
5.3 Software installation	23
5.4 Set the TCOMSYS01 clock	25
<b>6 Working with the system</b>	<b>27</b>
6.1 Basic functionality	27
6.2 Data retrieval	29
6.3 Example experiments	31
<b>7 Maintenance and trouble shooting</b>	<b>35</b>
7.1 Recommended maintenance and quality assurance	35
7.2 Trouble shooting	36
<b>8 Appendices</b>	<b>38</b>
8.1 Advanced settings	38
8.2 Ordering the TCOM01 sensor only	40
8.3 EU declaration of conformity TCOMSYS01	43
8.4 EU declaration of conformity TCOM01	44

## Introduction

TCOMSYS01 is a measuring system to help understand and quantify “causes and effect” leading to human thermal comfort. The TCOM01 body is temperature stabilised at 33 °C, so that it offers a relatively direct measurement of the human experience. In essence, TCOM01 is a miniature thermal mannequin, measuring according to the innovative Hot Cube method. The heater power required to keep the TCOM01 at a constant temperature is the main measurand. Incorporating 5 heat flux sensors with a black absorber, it also offers a detailed picture of the heat gain and loss from different directions, and a good indication of convective and radiative asymmetry. Other measurements are sensor body temperature, air temperature and relative humidity. In its standard configuration, the system consists of an MCU (Measurement and Control Unit) and a TCOM01 sensor. The MCU offers direct connection to any local area network and “Ethernet over USB”. TCOM01 is also available as a sensor only.



**Figure 0.1** *The TCOM01 sensor body on a tripod. TCOM01 is meant for surveys of thermal comfort as experienced by the human body. It is equipped with 5 x heat flux sensor (black surfaces) and a sensor body temperature sensor. Heater power, ambient temperature and relative humidity are measured in the accompanying MCU (Measurement and Control Unit)*

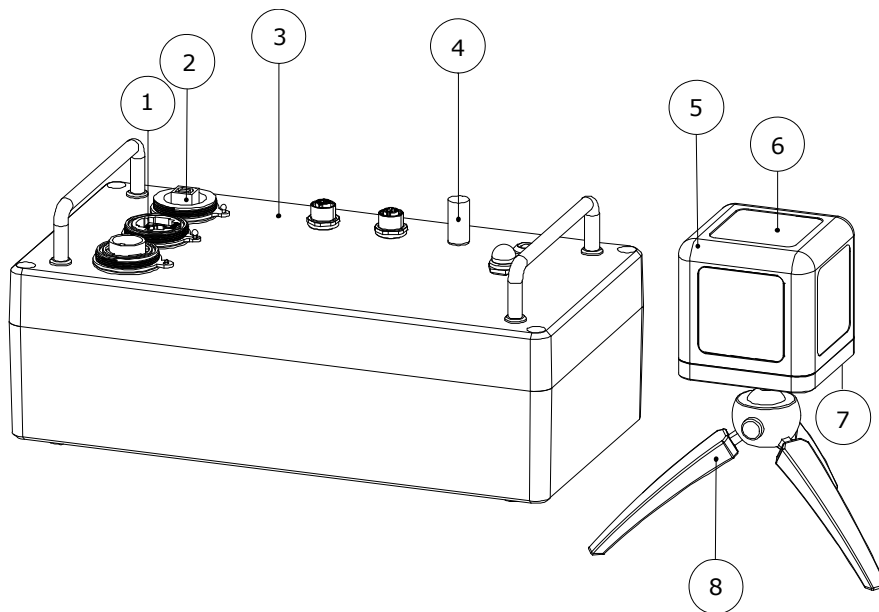

**Figure 0.2** Overview of TCOMSYS01: (1) Ethernet port, (2) USB port, (3) MCU Measurement and Control Unit, (4) air temperature and relative humidity sensor, (5) TCOM01, (6) side panel: heat flux sensor with black absorber foil, (7) connectors (not visible), (8) tripod

TCOMSYS01 was originally designed to study the effect of radiation sources on human comfort. Equipped with heat flux sensors that measure in 5 directions and a humidity and temperature probe, it offers a good picture of energy gains and losses from all sides to a metal body that thermally resembles the human body; the TCOM01 sensor is in essence a miniature thermal mannequin.

The TCOMSYS01 system employs dedicated sensors and electronics, measuring thermal comfort according to the new Hot Cube method. The high accuracy of the MCU (Measurement and Control Unit) ensures that TCOMSYS01 will still measure down to very low heat fluxes. The MCU has robust aluminium housing. The system generates a measurement file, including a time-stamp. The measurement data are stored in the MCU and are later downloaded to a PC. The user is responsible for data analysis.

### How to employ TCOMSYS01

The primary source of information from TCOMSYS01 simply is the power [W] required to keep the TCOM01 sensor at a constant temperature; a very direct measure of human comfort. This power may be compared to the power required at 20 °C ambient air temperature, no convection (zero wind speed) and no radiation. Power consumption will immediately show if there is a situation of overheating or heatstress or a situation of overcooling or coldstress.

The second direct information supplied by the heat flux sensors of TCOMSYS01 is the heat loss or gain [W/m<sup>2</sup>] as a function of direction. If radiative sources are dominant, TCOMSYS01 will measure radiative asymmetry.

A web browser may be used for real time measurement review, data collection and for changing control settings such as TCOM01 body temperature.

### TCOMSYS01 advantages

- direct representation of the human body
- helps understand and quantify the detailed physical cause and effect of thermal comfort
- simple experiments can be used to quantify the sources of heat gain or loss
- offers directional information
- good addition to Wet-Bulb Globe temperature measurement
- robust, student-proof
- "stand alone"; equipped with its own clock and memory
- safe, low voltage power supply
- communication by (virtual) Ethernet link
- user interface program on MCU



**Figure 0.3** A complete system for measuring thermal comfort

### Suggested use

- surveys of human thermal comfort
- studies of the effect of radiating sources
- workplace investigations
- car passenger comfort testing
- educational purposes, illustrating heat transfer
- bio-meteorology
- microclimate studies
- wind-chill analysis
- analysis of fabric insulation



**Figure 0.4** *TCOM01 applied in car passenger comfort testing*

## History

Already in 1929 the Eupatheoscope (from Greek “wellbeing–emotion–examination”) was designed by A.F. Dufton to quantify the condition in a room from the point of view of comfort. It consists of a blackened cylinder which is controlled to maintain a temperature of 23 °C. The power used is interpreted in terms of equivalent temperatures.

In the 1990 the company Bruel & Kjaer carried a thermal comfort meter (model 1212), based on the same principle, and in addition processing Fangers equation.

Both models involved only an integrated power measurement. The new Hot Cube method improves on this by incorporating omnidirectional heat flux measurements.

## What makes TCOMSYS01 different

The main contributors to thermal comfort are air temperature, air speed, radiant temperature and humidity. Apart from this, there are personal contributors such as metabolic rate and insulation by clothing. Many studies use Fanger’s thermal comfort equation as applied in EN ISO 7730: *Moderate Thermal Environments - Determination of the PMV and PPD indices and specification of the condition for thermal comfort*. Another approach utilises a globe temperature measurement: EN ISO 27243: *Hot environments. Estimation of the heat stress on working man, based on the WBGT Index (Wet Bulb Globe Temperature)*. These methods are quite indirect in particular when determining the heat flow from air speed and radiation.

- TCOMSYS01 offers heat flux measurements. This approach is a lot more direct than the indirect estimate from air speed and radiation.
- TCOMSYS01 offers directional information.
- TCOMSYS01 works at a realistic skin temperature of 33 °C (user adjustable).

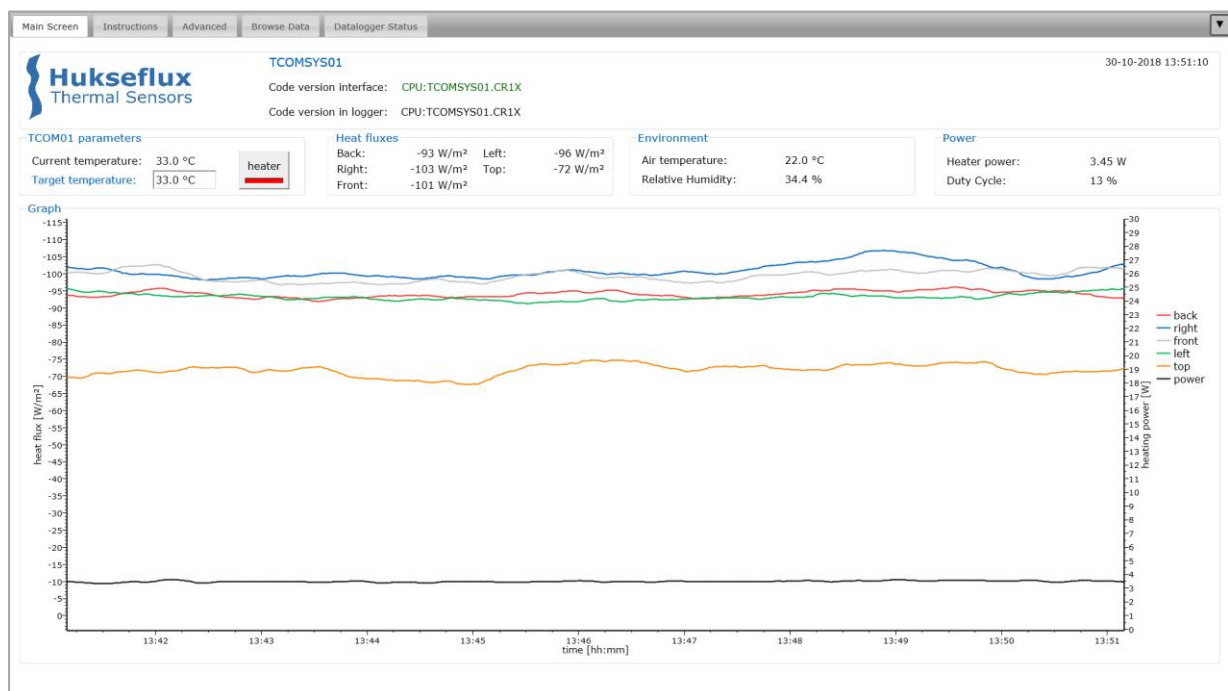

**Figure 0.5** TCOMSYS01’s user interface: the main screen shows live data, and a graph of the last 10 minutes



### Rated operating conditions

TCOMSYS01 is designed to work between +10 and +25 °C. In its standard configuration, uninsulated and stabilised at 33 °C, it is rated for operation in indoor conditions including significant radiative heating.

It will stabilise at 33 °C under approximately one of the following conditions:

- air speeds < 5 m/s
- irradiance < 400 W/m<sup>2</sup>
- ambient air temperature > 5 °C

Under other conditions, the sensor may not be able to stabilise its body temperature due to overheating (indicating overheating or heatstress) or shortage of electrical power (indication of overcooling or coldstress). Powered using a low voltage, TCOMSYS01 is safe to use.

TCOMSYS01 may be used for short-term outdoor experiments in the order of weeks. Under long-term exposure to solar radiation, the black heat flux sensor coating may become more reflective.

### User interface: MCU is a web server

The MCU serves as a web server, and can be connected to any local area network. No more downloading of USB drivers and special interface software! Alternatively it offers an "Ethernet over USB" or virtual Ethernet link, where you connect to the MCU using a USB cable. If you type into your web browser the MCU's IP address (192.168.66.1 by default), you have access to the user interface.

### Ordering the TCOM01 sensor only

The sensor TCOM01 is also available as a "sensor only". The configuration then includes the mannequin with 5 x heat flux, 1 x temperature, 1 x heater, 2 x cable, 2 x chassis connector and 1 x tripod. The user then must combine it with his or her own measurement and control unit.

### Options

- TCOM01 sensor only
- extended rated operating conditions; temperature, irradiance, wind speed

### See also

- our complete [product range of heat flux sensors](#)
- view the [TRSYS01](#) building thermal resistance measuring system which includes 2 x HFP01 sensor and 4 x matched thermocouple type K



**Figure 0.6** TCOM01 is also available as a "sensor only"

# 1 Ordering and checking at delivery

## 1.1 Ordering TCOMSYS01

The standard configuration of TCOMSYS01 is with 2 x 1.5 m cable

Common options are:

- TCOM01 sensor only (see the appendices of this user manual for what is included)
- extended rated operating conditions; temperature, irradiance, wind speed

## 1.2 Included items

Arriving at the customer, the delivery should include:

- 1 x HPRC 2500 carrying case
- 1 x TCOMSYS01 thermal comfort measuring system
  - 1 x TCOM01 thermal comfort sensor
  - 1 x MCU Measurement and Control Unit
- 1 x 5 pin PHOENIX CONTACT cable, 1.5 m
- 1 x 8 pin PHOENIX CONTACT cable, 1.5 m
- 1 x Manfrotto PIXI EVO 2 tripod
- 1 x USB cable with Bulgin connector, 2 m
- 1 x Bulgin connector for Ethernet cable
- 1 x 12 VDC adapter, 1 m, supplied with 4 interchangeable AC plugs (AUS, EU, GBR, USA)
- 1 x product certificate



**Figure 1.2.1** *TCOMSYS01 with its MCU and carrying case*

## 2 Instrument principle and theory

### 2.1 MCU Measurement and Control Unit

The MCU Measurement and Control Unit is specified to measure the current draw of the heater, the voltage output of the heat flux sensors and the resistance of the 10 k $\Omega$  thermistor (for TCOM01 body temperature).

The MCU performs the calculation of heater power, heat fluxes and temperature. It acts as a PID controller to stabilise the TCOM01 body temperature at the required temperature. The default setting of the body temperature is 33 °C. This may be adjusted via the user interface.

The MCU interfaces with the humidity module to provide an ancillary measurement of ambient air temperature and relative humidity.

The software, calibration data and user interface are stored on the MCU.

The MCU stores measurement data on a 8 GB Micro SD card.

#### 2.1.1 Ambient air temperature and relative humidity

The MCU interfaces with a Vaisala HMM105 humidity module, to provide an ancillary measurement of ambient air temperature and relative humidity.

## 2.2 TCOM01 sensor body

The TCOM01 sensor body is an aluminium body that is stabilised at a default temperature of 33 °C. It is equipped with five FHF01 heat flux sensors with black absorbers to monitor radiative and convective losses in five directions.

The connectors are in the 'neck' of the TCOM01, this defines the orientation of the black surfaces (top, front, left, right, back).

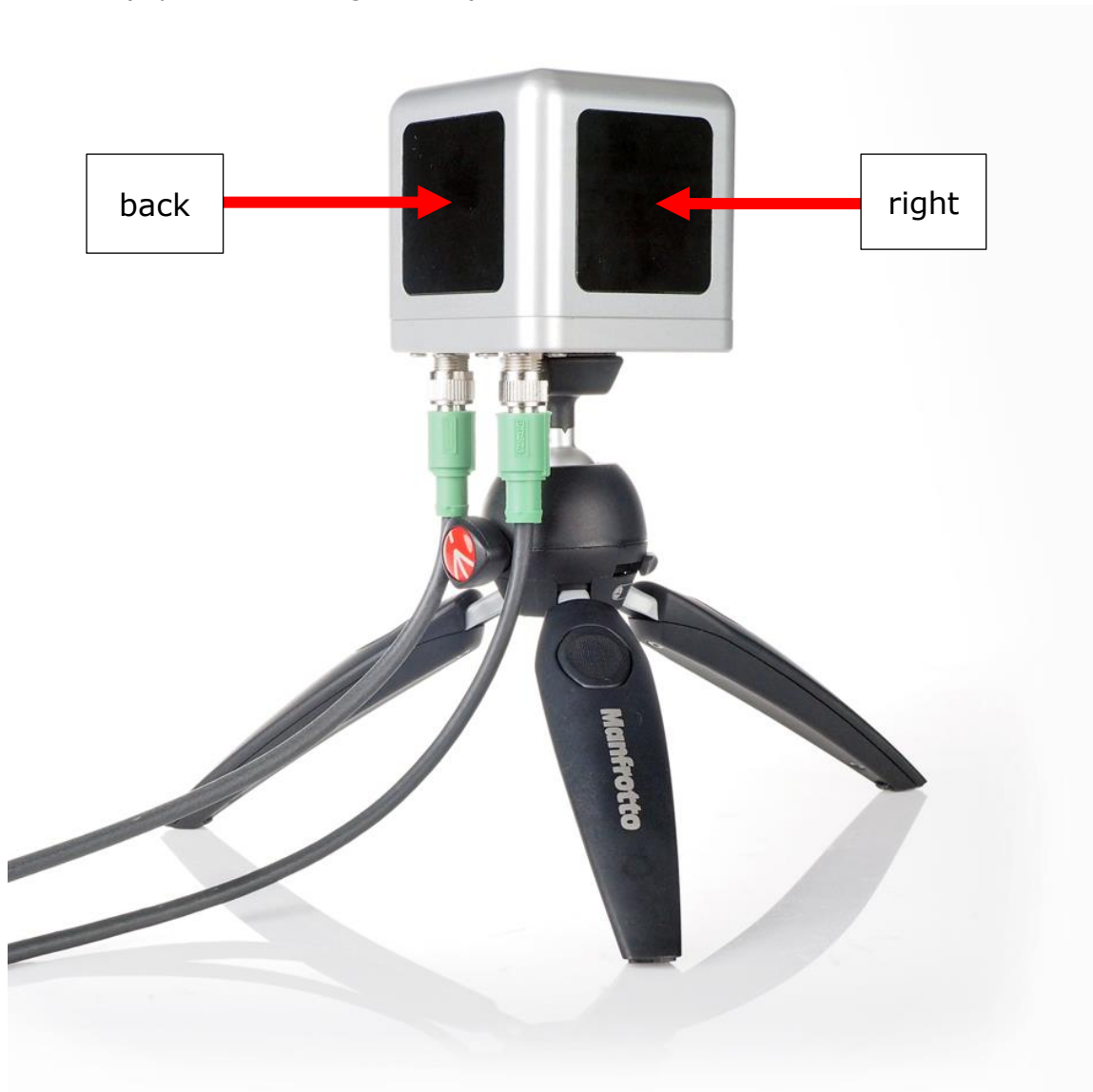

**Figure 2.2.1** TCOM01 consists of an aluminium body (1) that is stabilised at a user adjustable 33 °C using an internal heater. It is equipped with five FHF01 heat flux sensors (2) with a black absorptive coating and an internal sensor body temperature measurement

### 2.2.1 Heater

TCOM01 is powered using a thin film heater of around 4 Ohm, with a maximum power rating of 40 W. The heater power is measured using a current measurement in the MCU and combines this with the electrical resistance of the heater and a correction for the voltage drop over the cables. The exact heater resistance is part of the system calibration.

Temperature stabilisation of the TCOM01 body is achieved by pulse width modulation on the power supplied to the heater. The 'duty cycle' (the percentage of time the heater is powered) of this pulse width modulation is determined by the PID controller.

### 2.2.2 FHF01 foil heat flux sensors

The incorporated heat flux sensors are Hukseflux model FHF01 foil heat flux sensors. FHF01s measure the heat flux density through the surface of the sensor. This quantity, expressed in  $W/m^2$ , is called heat flux. Working completely passive, using a thermopile sensor, FHF01s generate a small output voltage proportional to this flux.

All FHF01s are individually calibrated, and their sensitivities are programmed into the software. The sensitivities can also be found on the product certificate.

For more information on FHF01, please refer to the FHF01 user manual.

To make the heat flux sensors sensitive not only to convective heat flux but also to radiative heat flux, the FHF01s are covered with an adhesive black foil.

### 2.2.3 Body temperature sensor

Body temperature is measured using a 10 k $\Omega$  thermistor inside the TCOM01 body. The MCU measures the resistance of this thermistor and converts this to temperature.

## 3 Specifications of TCOMSYS01 Hot Cube

TCOMSYS01 is a measuring system for “causes and effect” analysis leading to human thermal comfort. The measurement method is called Hot Cube method. The TCOM01 body is temperature stabilised, normally at 33 °C. The heater power required to keep the TCOM01 at a constant temperature is the main measurand. TCOM01 includes 5 heat flux sensors with a black absorber, measuring the heat gain and loss from different directions. Other measurements are sensor body temperature, air temperature and relative humidity.

**Table 3.1** Specifications of TCOMSYS01 (continued on next page)

<b>TCOMSYS01 HOT CUBE SPECIFICATIONS</b>	
Description	thermal comfort measuring system
Measuring method	Hot Cube method
Measurand	heating power for stabilisation
Measurand in SI units	power in W
Measurand	heat flux (5 x)
Measurand in SI units	heat flux density in W/m <sup>2</sup>
Measurand	TCOM01 body temperature
Measurand in SI units	temperature in °C
Measurand	ambient air temperature
Measurand in SI units	temperature in °C
Measurand	relative humidity
Measurand in SI units	relative humidity in %
TCOM01 heat flux sensors	5 x FHF01 foil heat flux sensor
TCOM01 temperature sensor	10 kΩ thermistor
TCOM01 heater	3.6 Ω (nominal value), 40 W
Limiting temperature range	-25 to +50 °C
Thermal fuse protection limit	60 °C; to reset the thermal fuse, cool down the TCOM01 and turn the MCU [OFF]
Temperature setting	33 °C (user adjustable)
Start up interval	< 10 min
Standard rated operating temperature range (for temperature stabilisation)	10 to 25 °C
Rated air speed for temperature stabilisation	< 2 m/s
Rated irradiance for temperature stabilisation	< 400 W/m <sup>2</sup>
IP protection class	IP65 (TCOM01) IP65 (MCU)
Rated operating relative humidity range	0 to 100 %
Included cables	2 x cable with 2 connectors (1.5 m) USB cable (2 m) connector for waterproof Ethernet connection
Data display	in web browser
Mounting	photo-tripod with ¼ inch -20 UNC screw Manfrotto Pixi EVO 2 section black tripod is included
Gross weight TCOMSYS01 system including carrying case and packaging	approx. 10 kg
Net weight TCOMSYS01 system including carrying case	approx. 8 kg
Carrying case TCOMSYS01 system	case of 480 x 385 x 190 mm



**Table 3.1** Specifications of TCOMSYS01 (started on previous page, continued on next page)

Gross weight TCOM01 sensor including carrying case and packaging	approx. 4.5 kg
Net weight TCOM01 sensor including carrying case and packaging	approx. 3 kg
Carrying case TCOM01 sensor	case of 335 x 286 x 155 mm
Net weight	approx. 1 kg (TCOM01) approx. 1.5 kg (TCOM01 with tripod) approx. 4 kg (MCU)
Storage	TCOM01 and MCU should be stored in a dry place.
<b>MCU</b>	
User interface	on MCU as a web page
Connection	via LAN or "Ethernet over USB"
Datalogger	Campbell Scientific CR1000X Measurement and Control Datalogger
Datalogger specifications	see CR1000X manual (available from <a href="https://www.campbellsci.com/cr1000x">https://www.campbellsci.com/cr1000x</a> )
Voltage measurement accuracy	$4 \times 10^{-6}$ V (0.8 W/m <sup>2</sup> )
Memory card	8 GB Micro SD card, industrial grade
Sample rate	1/min (user adjustable)
Stored measurement definition	operator name, comment, averages of heater power, heat fluxes, TCOM01 body temperature, heating flag, duty cycle of pulse width modulation, ambient air temperature, relative humidity, datalogger supply voltage  data storage interval and averaging period adjustable by user
Data Storage capacity	2 GB > 1 year of data
MCU rated power supply	10 to 16 VDC
Power switch / LED	red LED [ON] when power is supplied to MCU
Internal system battery	AA, 2.4 Ahr, 3.6 VDC for battery-backed memory and clock only
<b>ADAPTER 12 VDC</b>	
Adapter rated power supply	90 - 264 VAC, 50 / 60 Hz, output 12 V - 4.2 A
<b>FHF01 HEAT FLUX SENSOR</b>	
Specifications	see FHF01 manual (available from <a href="https://www.hukseflux.com/product/fhf01">https://www.hukseflux.com/product/fhf01</a> )

**Table 3.1** *Specifications of TCOMSYS01 (started on previous pages)*

<b>INSTALLATION AND USE</b>	
Performing a representative measurement	see the chapter on general directions for performing a measurement of thermal comfort
Installation	see the chapter on installation
Cables	use TCOMSYS01 with its original cables
Cable extension	TCOMSYS01 cables cannot be extended. contact Hukseflux if longer cable lengths are required
<b>CALIBRATION AND FUNCTIONAL TEST</b>	
Production report	included
Performance verification	via functional test
Calibration traceability	FHF01, temperature sensors, heater resistance and MCU are traceable to SI units
Calibration uncertainty heat flux sensors FHF01	$\pm 5\%$ ( $k = 2$ )
Calibration uncertainty heater resistance	$\pm 5\%$ ( $k = 2$ )
Recommended maintenance interval	see the chapter on recommended maintenance and quality assurance
<b>MEASUREMENT ACCURACY</b>	
Uncertainty of the measurement	statements about the overall measurement uncertainty can only be made on an individual basis. refer to the FHF01 manual for more information on the measurement uncertainty of the FHF01 heat flux sensors.

### 3.1 Dimensions of TCOMSYS01

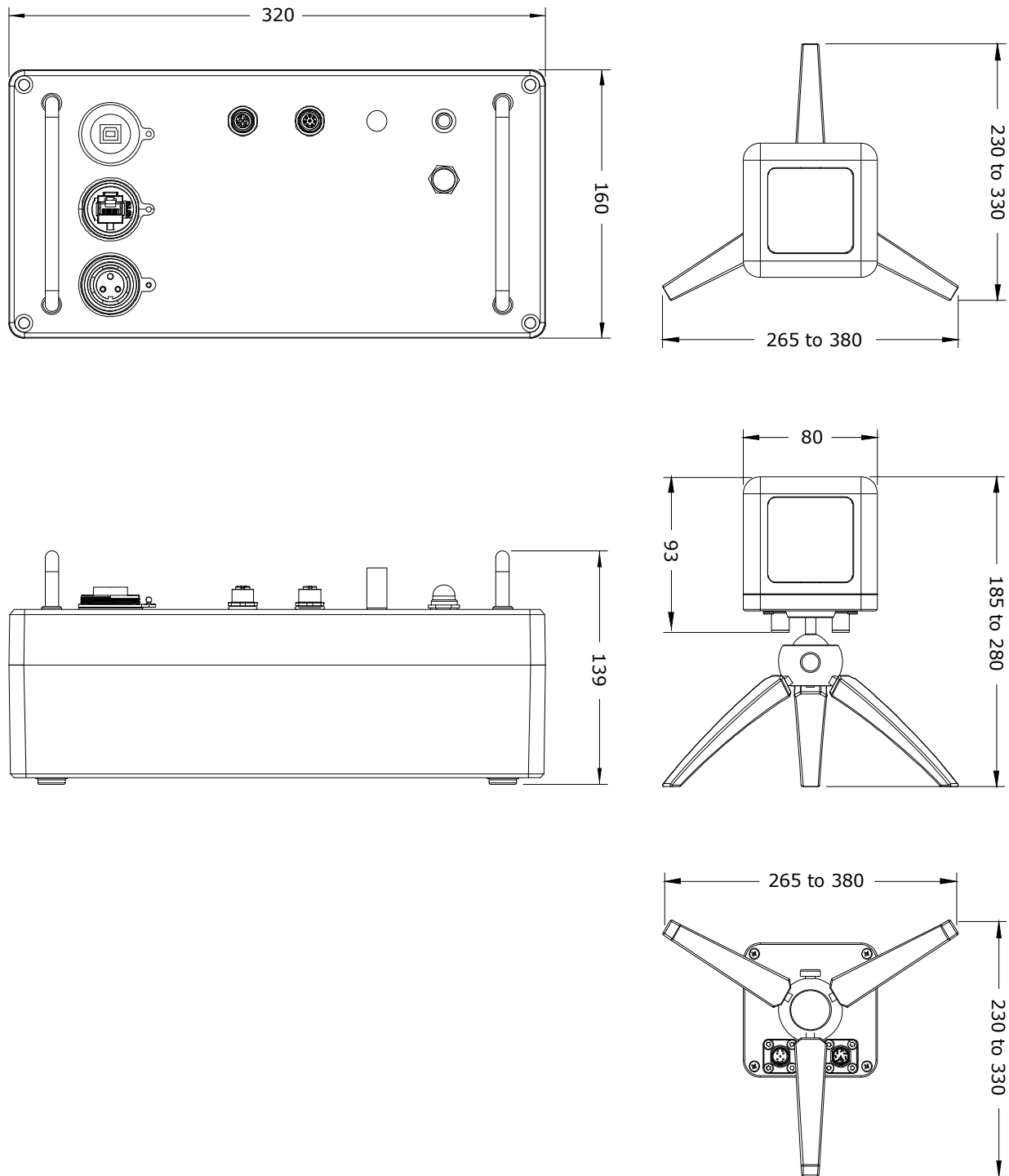

**Figure 3.1.1** Dimensions of TCOMSYS01 in  $\times 10^{-3}$  m

## 4 General directions for performing a measurement of thermal comfort

TCOMSYS01 is designed to measure thermal comfort.

Allow time for the TCOM01 body to reach its temperature setting and stabilise before starting an experiment. To reduce the start up time, an insulating cover may be used to insulate the TCOM01 while heating up.

The TCOM01 body is temperature stabilised at 33 °C by default. To determine thermal comfort, monitor the power required to maintain this temperature.

As a secondary measurement, monitor the heat fluxes from five sides of the TCOM01 body to quantify heat gains and losses, including their directions. A positive heat flux reading indicates a heat gain (heat flowing into the TCOM01), a negative heat flux reading indicates a heat loss (heat flowing out of the TCOM01).

To study the exact effect of radiative sources, in many cases a simple experiment, like switching a radiation source [ON] and [OFF] or shielding a radiation source, can be used to distinguish between convective and radiative heat transport.

Far-infra red radiation sources may be studied by temporary shielding with silicon wafer. Silicon has around 50 % transmission. Radiation from the sun or lamps may be quantified by shading and unshading, using a non-transparent screen like a metal sheet.

To study the insulating effect of clothing, TCOM01 may be insulated using the same fabrics.

A web browser may be used for real time measurement review, and for changing control settings such as TCOM01 body temperature and control of the data storage.

TCOMSYS01 is designed to work between +10 and + 25 °C. In its standard configuration, uninsulated and stabilised at 33 °C, it is rated for operation in indoor conditions including significant radiative heating. It will stabilise at 33 °C under approximately the following conditions:

- air speeds < 5 m/s
- irradiance < 400 W/m<sup>2</sup>
- ambient air temperature > 5 °C

Under other conditions, the sensor may not be able to stabilise its body temperature due to overheating (indicating overheating or heatstress) or shortage of electrical power (indication of overcooling or coldstress).

## 5 Installation

### 5.1 Electrical connection

All sensors are pre-wired in the MCU. Use TCOMSYS01 with its original cables.

Connect both cables between the TCOM01 and the MCU. This must be done before turning on the system. Table 5.1.1 and Table 5.1.2 provide the pinout of the connectors.

Make sure to screw the cable connectors tightly.

**Table 5.1.1** connections Cable 1

PIN	
1	heat flux top [+]
2	heat flux right [+]
3	heat flux front [+]
4	heat flux left [+]
5	heat flux back [+]
6	heat flux (all) [-]
7	10 kΩ thermistor [+]
8	10 kΩ thermistor [-]

**Table 5.1.2** connections Cable 2

PIN	
1	heater [+]
2	heater [+]
3	heater [-]
4	heater [-]
5	not connected



**Figure 5.1.1** TCOM01 connected to MCU using two cables

## 5.2 Mechanical setup

TCOMSYS01 comes with a small aluminium photo tripod.

Screw the tripod onto the bottom of the TCOM01 to provide a stable platform, using the ¼" screw connection. This screw connection is a standard in photography. The TCOM01 can also be used with different tripods.



**Figure 5.2.1** *TCOM01 on its tripod*

The TCOMSYS01 comes with a power adapter. Plug the adapter into your power outlet and connect the Bulgin connector of the power supply to the '12VDC' connector on the MCU. Ensure both cables between the TCOM01 and the MCU are connected.

Turn the system [ON] by pressing the grey 'Power' button on the MCU. The red LED should light up.

The system will start collecting data immediately. TCOMSYS01 will measure and collect data as long as power is provided to the system, even without an active connection to the interface.

### 5.3 Software installation

The TCOMSYS01 is operated using a web-based browser, which is pre-loaded on the SD card. This chapter explains how to get access to the interface. For more setup options, refer to the appendix on advanced settings.

To connect to the interface, you have two options:

#### 5.3.1 Direct Ethernet connection

Connect an Ethernet cable to the 'RJ45' connector on the MCU and plug this into your Local Area Network (LAN). You may use the supplied Bulgin connector for a more secure and weatherproof connector.

The system will be assigned an IP address automatically.

Open your web browser and enter 'TCOMSYS01/' in your address bar.

If your network does not allow for systems to assign their own name, you need to manually enter the IP address of the TCOMSYS01.

To find the IP address, you can use the Campbell Scientific LoggerLink app, available from <https://www.campbellsci.com/loggerlink>.

In the LoggerLink app, you can search for dataloggers on your network using the search function under 'TCP settings'.

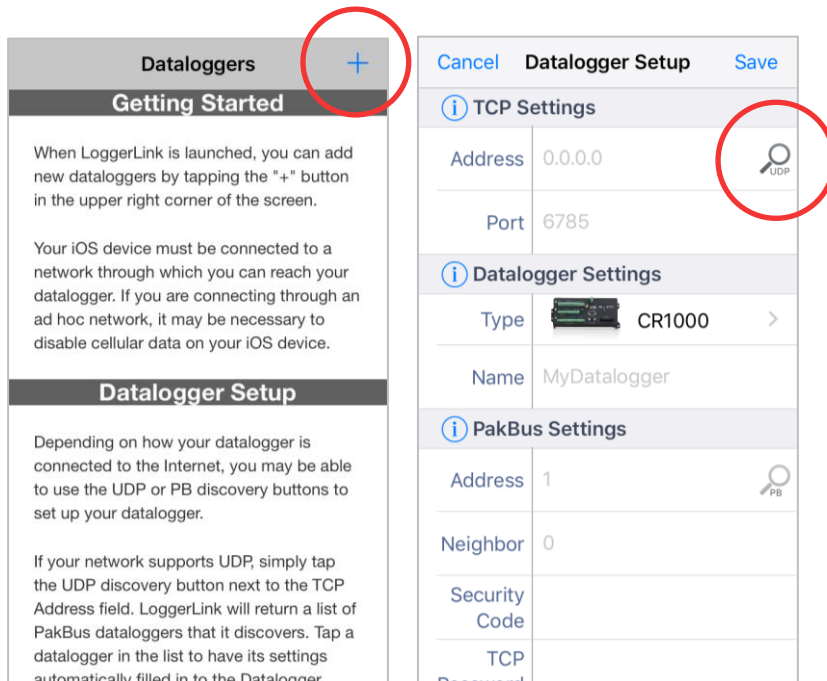
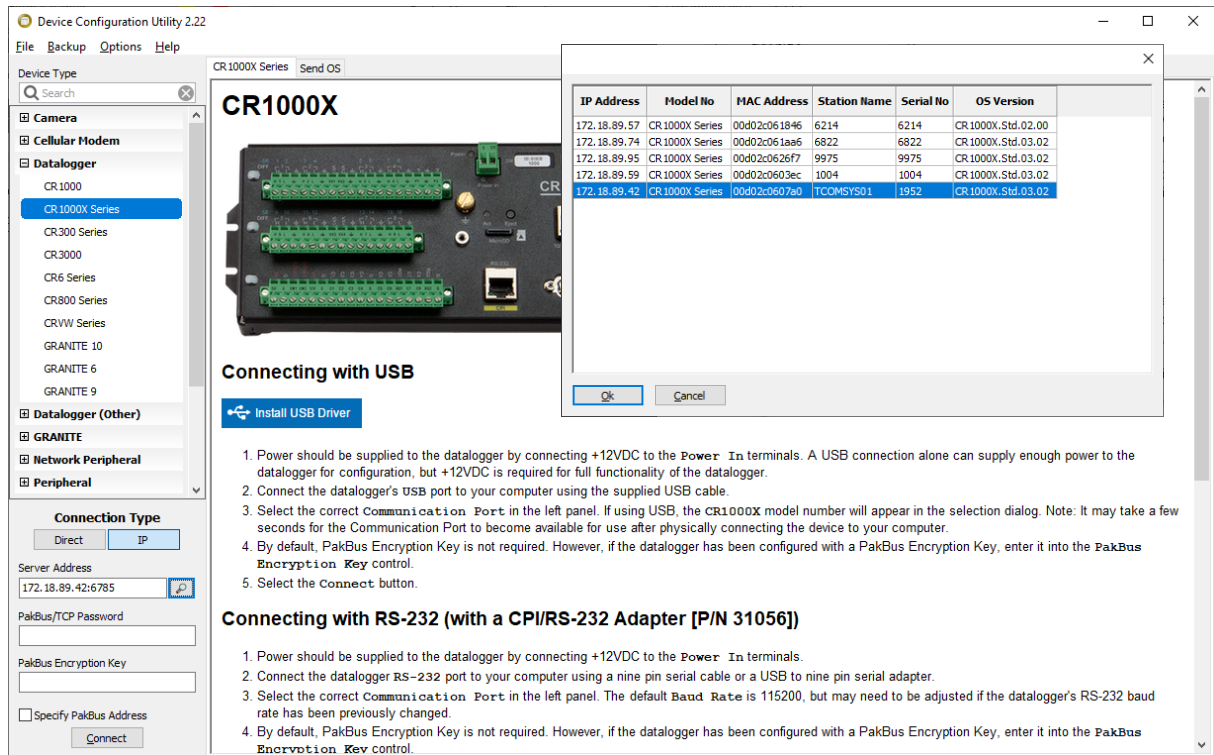

**Figure 5.3.1.1** Using the LoggerLink app to find TCOMSYS01's IP address

Alternatively, you can search for the TCOMSYS01 using the Campbell Scientific Device Configuration Utility, available from <https://www.campbellsci.com/devconfig>.

In the Device Configuration Utility, select 'CR1000X Series' under the 'Datalogger' options, make sure to select 'IP' and click the 'looking glass' next to the 'Server Address' field.

When you have found the IP address of the TCOMSYS01, open your web browser and type the IP address in your address bar.



**Figure 5.3.1.2** Using the Device Configuration Utility to find TCOMSYS01's IP address



### 5.3.2 Ethernet over USB connection

Plug the USB cable into the 'USB' connector on the MCU and connect to your PC. The drivers should be installed automatically. Once this process is complete, open your web browser and enter the IP address for the USB port into your address bar. By default, this is 192.168.66.1.

If the drivers are not automatically installed, install the USB drivers using the Campbell Scientific Device Configuration Utility available from

<https://www.campbellsci.com/devconfig>.

Under 'Datalogger', select 'CR1000X series' and choose 'Install USB Driver'.

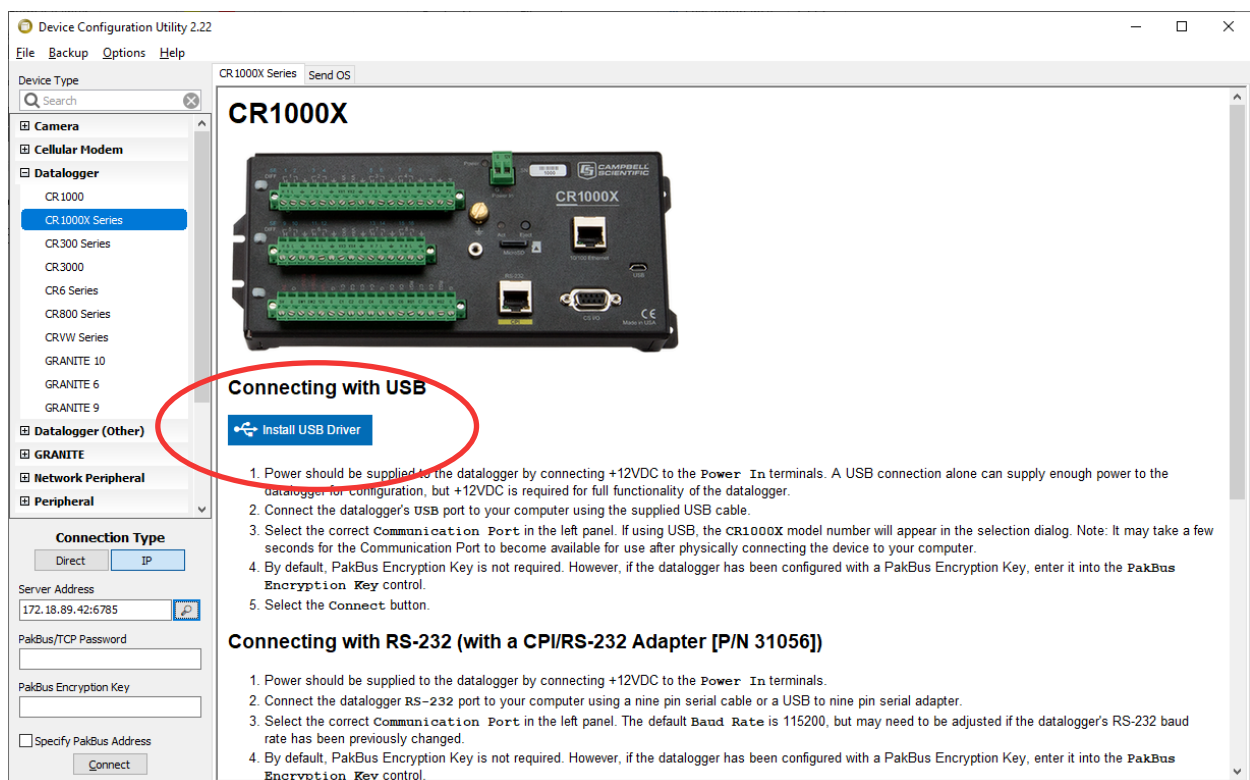

**Figure 5.3.1.2** Using the Device Configuration Utility when drivers are not installed automatically

## 5.4 Set the TCOMSYS01 clock

### 5.4.1 Via Ethernet connection

Connect to the TCOMSYS01 using the Campbell Scientific LoggerLink app.

In the 'Status' menu, scroll down to the bottom and choose 'Set Clock'.

You can choose to set the clock to the server time, or set a time manually.

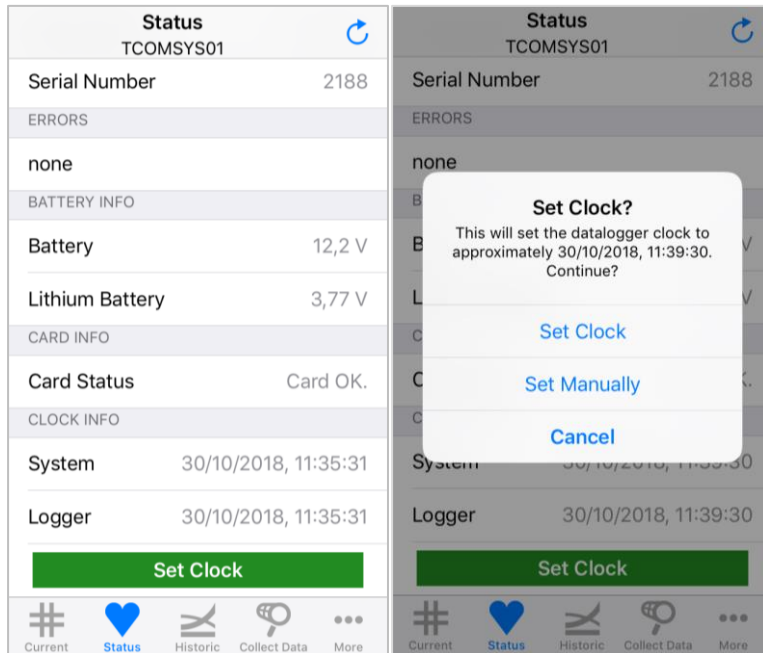

**Figure 5.4.1.1** Using the LoggerLink app when setting the TCOMSYS01 clock over Ethernet

#### 5.4.2 Via Ethernet over USB connection

Connect to the TCOMSYS01 using the Campbell Scientific Device Configuration Utility. Under 'Logger Control', choose 'Set Clock' to set the TCOMSYS01 time to the reference time.

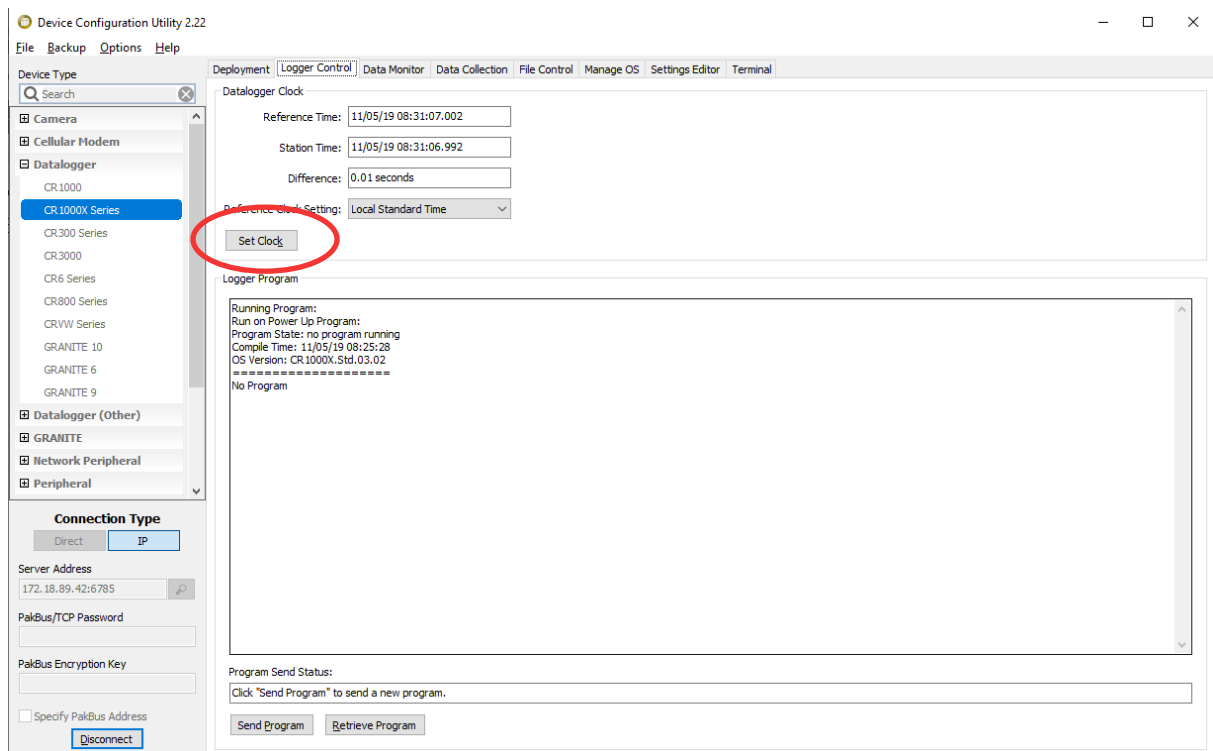

**Figure 5.4.2.1** Using the Device Configuration Utility when setting the TCOMSYS01 clock via Ethernet over USB

## 6 Working with the system

The user should be familiar with the warning statements indicated on page 2 of this manual.

### 6.1 Basic functionality

The 'Main Screen' of the interface shows a live display of the TCOMSYS01 measurement.

It gives live numerical data of the TCOM01 temperature, the measured heat fluxes in all five directions, the environmental parameters and heater power used to maintain the TCOM01 temperature.

Also, a graph is shown with data of the last 10 minutes.

It is possible to zoom in on the graph by drawing a rectangle with your mouse. Right click on the interface to open a menu with options to 'Show All Data' or 'Restore' to the original view.

In the top right corner, the TCOMSYS01 date and time are shown.

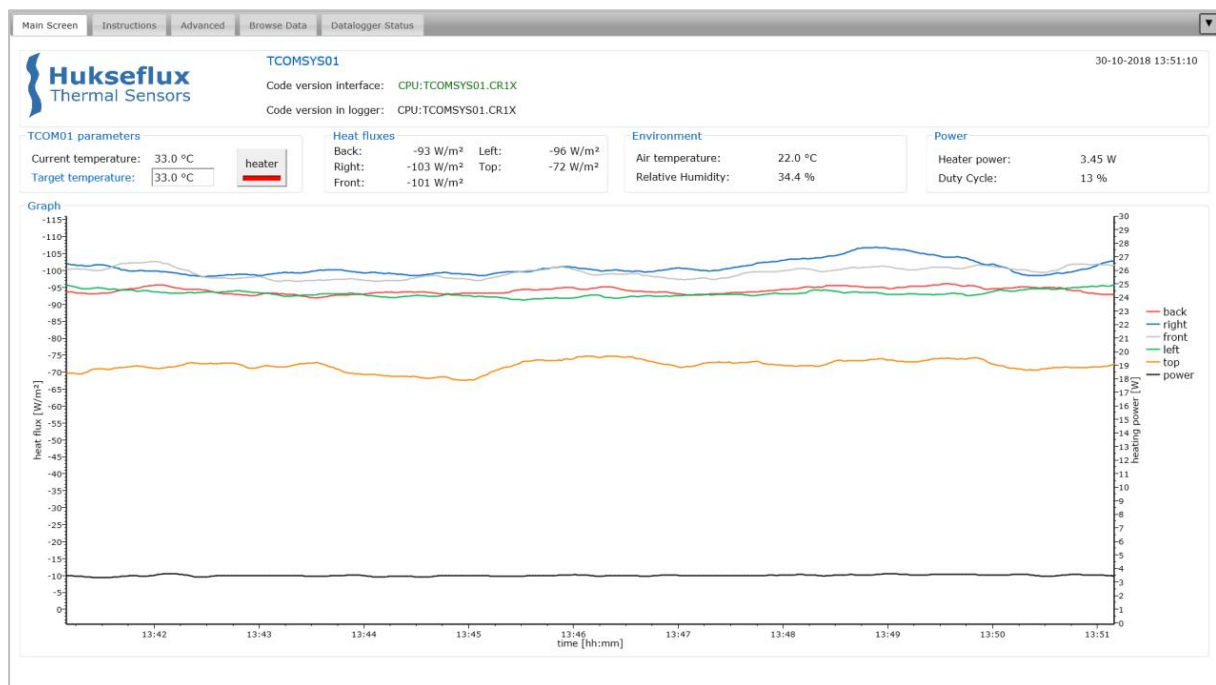

**Figure 6.1.1** TCOMSYS01 main screen shows live data, and a graph of the last 10 minutes.

In the main screen, it is possible to change the TCOM01 temperature setting by changing 'Target temperature'. It is possible to turn the heater ON or OFF by pressing the 'heater' button. The red bar will light up if the heater is turned ON.

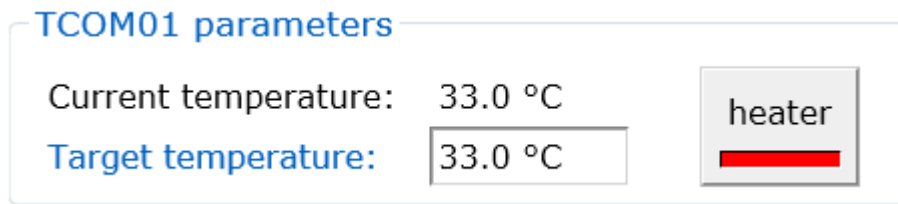

**Figure 6.1.2** In the TCOM01 parameters field, it is possible to change the TCOM01 target temperature and turn the heater ON and OFF

The first time you want to change something in the interface, the system will ask for a user name and password. These can be found on the product certificate. The default user name is TCOMSYS01, the default password is the serial number of the system.

Check whether all variables make sense:

**Table 6.1.1** expected values for measured variables

MEASURAND	EXPECTED VALUE
TCOM01 body temperature	equal to target temperature, within $\pm 0.2$ °C stable within $\pm 0.2$ °C
Heat fluxes	-50 to -150 W/m <sup>2</sup> in standard conditions influenced by convective and radiative sources noise level depends on activity
Air temperature	equal to room temperature
Relative humidity	0 to 100 %
Heater power	0 to 40 W
Duty cycle	0 to 100 %

## 6.2 Data retrieval

To retrieve data from TCOMSYS01, you can work from the 'Browse Data' tab of the interface.

Data of the TCOMSYS01 is stored in several tables, the relevant measurement data is in the TCOMSYS01Data table.

To view the last record, click on the 'TCOMSYS01Data' link.

To retrieve data, click 'custom' next to 'TCOMSYS01Data'.

This will open a custom data query window. There are several options for resulting data format and data query mode, see Table 6.2.1.

For further analysis, choosing a TOA5 data format is usually most convenient.

[refresh](#)

## Data Browser

- [Status](#) - (custom)
- [TCOMSYS01Data](#) - (custom)
- [DataTableInfo](#) - (custom)
- [Constants](#) - (custom)
- [Public](#) - (custom)

## Custom Data Query

Data Query URI	d1:TCOMSYS01Data
Resulting Data Format	toa5 ▼
Data Query Mode	date-range ▼
Enter Begin Date/Time	2018-10-29 00:00:00
Enter End Date/Time	2018-10-30 00:00:00
<input type="button" value="Get Data"/>	

**Figure 6.2.1** Clicking 'custom' in the Data Browser allows for a custom data query. The image on the right depicts an example of data retrieval from the TCOMSYS01. These settings will download a comma separated file with data from one specific day.

**Table 6.2.1** *data retrieval definition and settings*

Stored measurement definition	operator name, comment, averages of heater power, heat fluxes, TCOM01 body temperature, heating flag, duty cycle of pulse width modulation, ambient air temperature, relative humidity, datalogger supply voltage  (Averaging period is adjustable by user. By doing so the data storage interval is altered.)
Resulting data format options	html (hypertext markup language) json (java script object notation) toa5 (table output ascii version 5) tob1 (table out binary version 1) xml (extensible markup language)
Data query mode options	most-recent (most recent number of records) since-time (all data since a certain time) since-record (all data since a certain record number) data-range (all data within a certain time interval) backfill (most recent amount of seconds)

## 6.3 Example experiments

To become familiar with TCOMSYS01, we recommend the following tests. Perform all tests in a stable indoor condition. Before every test, make sure the TCOM01 is fully stabilised at its default temperature setting of 33 °C.

### 6.3.1 Change the TCOM01 temperature setting

By default, the TCOM01 temperature is stabilised at 33 °C. Change this setting to 37 °C by changing the value of the 'Target temperature' to 37 °C.

TCOMSYS01 will increase the heating power to reach the new requested value, and then stabilise around a higher heater power. The radiative and convective heat losses to the environment will also increase, as the temperature difference between the TCOM01 and the environment becomes larger.

This is also expected from a conservation of energy standpoint. When the TCOM01 temperature is constant, all the energy that is dissipated within the TCOM01 is lost to environment.

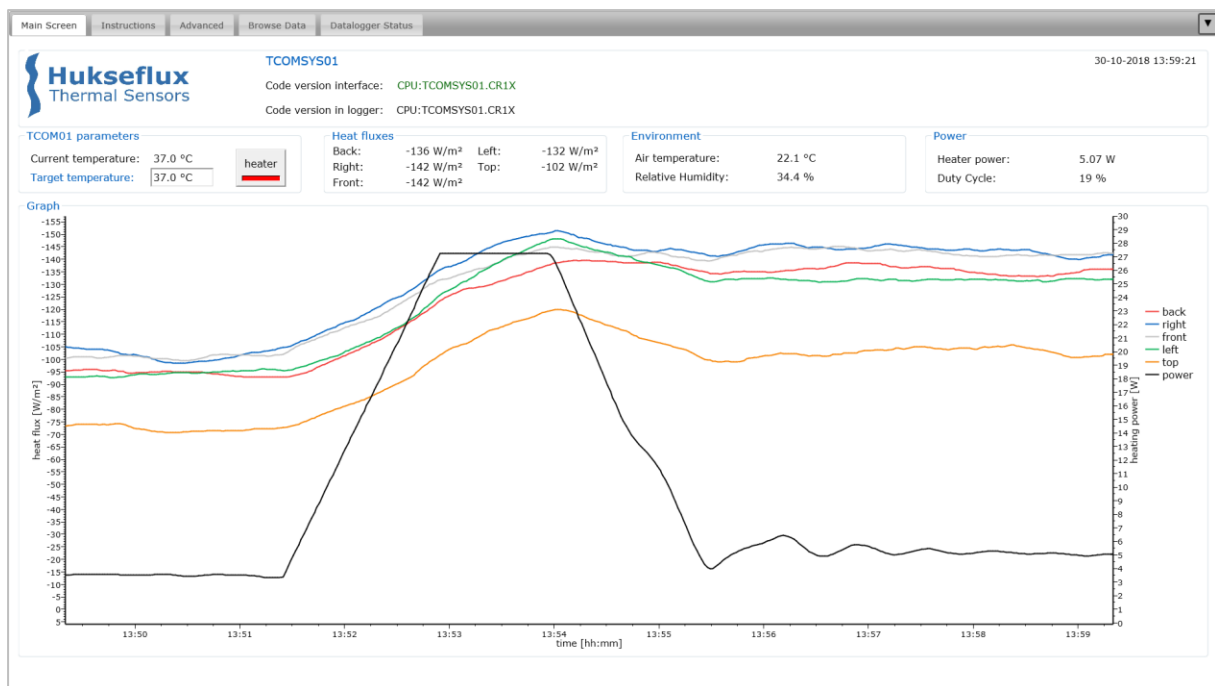

**Figure 6.3.1.1** TCOMSYS01 experiment: increase the target temperature. Heater power stabilises at a higher value, heat losses to the environment increase

### 6.3.2 Touch the different sides of TCOM01

Touch the black adhesive foils on the five different sides with your bare hand. The corresponding heat flux sensor should react. After releasing the sensor, the heat flux signal should slowly return to the original value.

Your hand is colder than TCOM01; the TCOM01 side you are touching will lose more heat by conduction.

Also, the power required to maintain the TCOM01 temperature will increase to compensate for the increased heat loss.

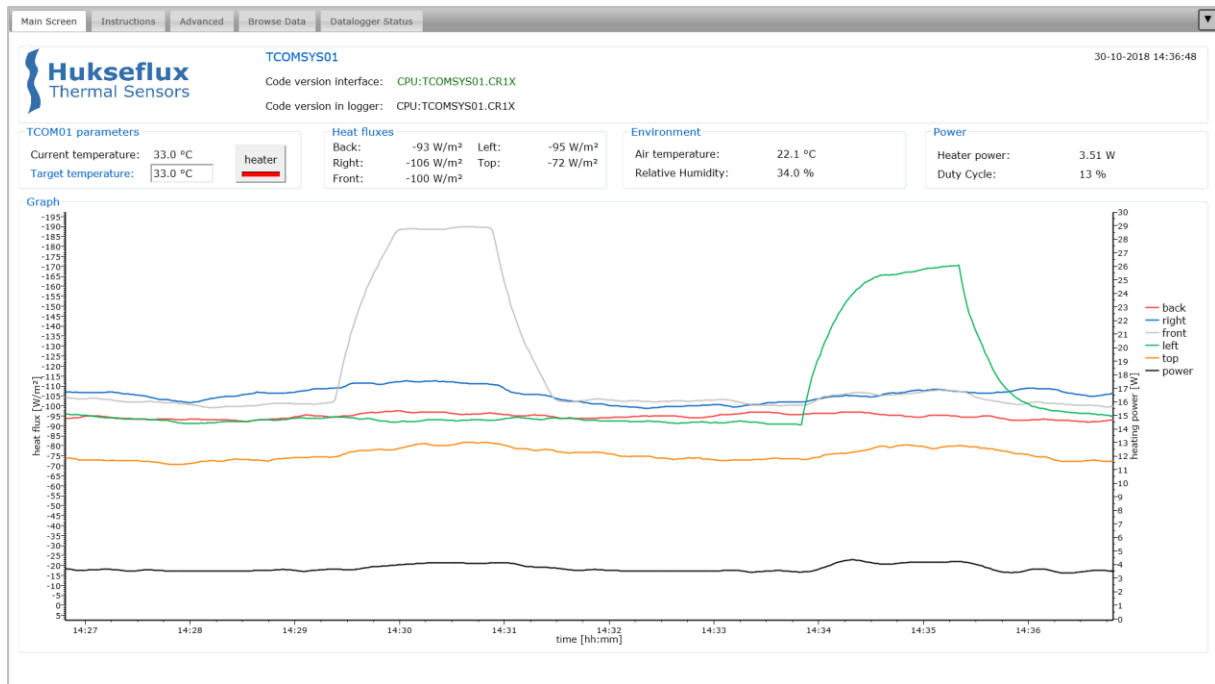

**Figure 6.3.2.1** TCOMSYS01 experiment: touch the TCOM01 with your hand. First, the front of the TCOM01 is touched for 30 seconds. 3 minutes later, the left side of the TCOM01 is touched for 30 seconds. Heat loss to the touched side of the TCOM01 is temporarily increased. The power required for stabilisation is slightly increased to compensate.



### 6.3.3 Blow ambient air on one side of TCOM01

Blow ambient air on one side of TCOM01 using a fan. The heat flux sensors should react. The heat flux sensor on the opposite side of the TCOM01 should show the least reaction. When you turn the fan off, the heat flux signals should slowly return to their original values.

TCOM01 is warmer than the environment. By increasing the air speed, you increase convective heat losses from the TCOM01 to the environment.

Also, the power required to maintain the TCOM01 temperature will increase.

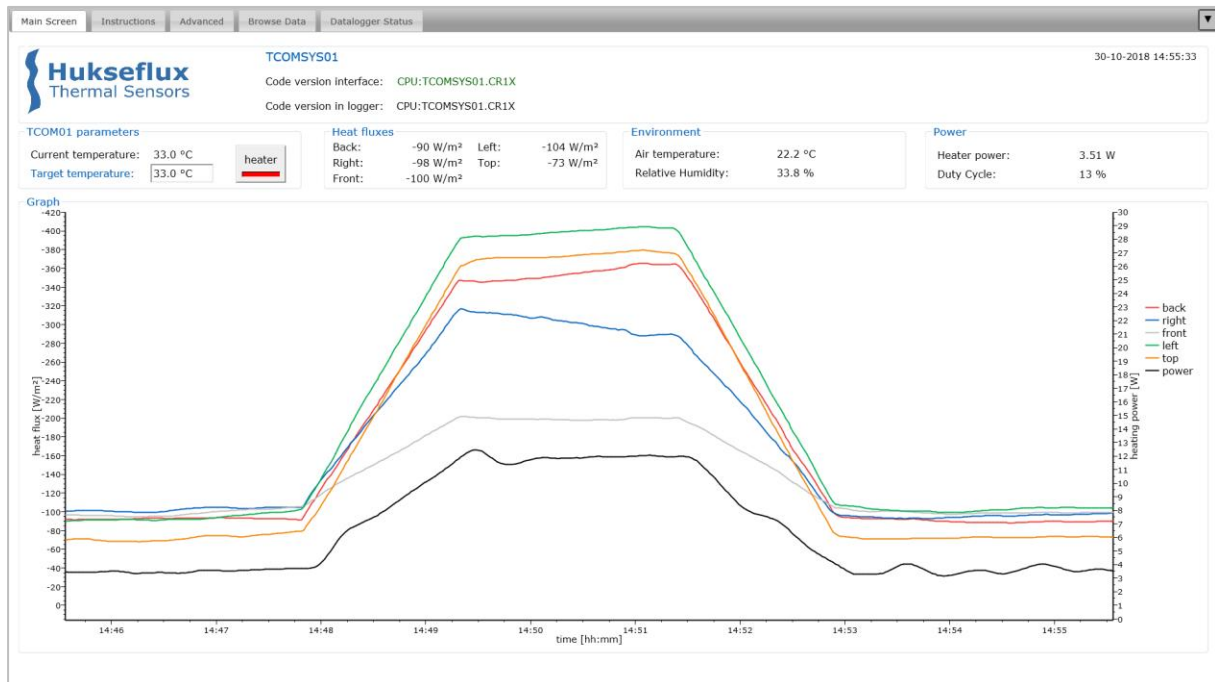

**Figure 6.3.3.1** TCOMSYS01 experiment: blow air on the TCOM01 with a fan. For 4 minutes, air is blown on the back of the TCOM01 with a small fan. All heat losses increases, the front of the TCOM01 is least affected. The power required to maintain the TCOM01 temperature increases as well. Afterwards, everything returns to its original values.

### 6.3.4 Expose one side of TCOM01 to a strong light source

Shine on one side of TCOM01 with a lamp. The heat flux sensor should react. Turn off the lamp. The heat flux sensor should slowly return to its original value.

A lamp is source of radiative heat (both in the shortwave and the longwave spectrum). The black adhesive foil on the exposed heat flux sensor absorbs this heat and it flows into the TCOM01 (a positive heat flux).

The power required to maintain the TCOM01 temperature will decrease.

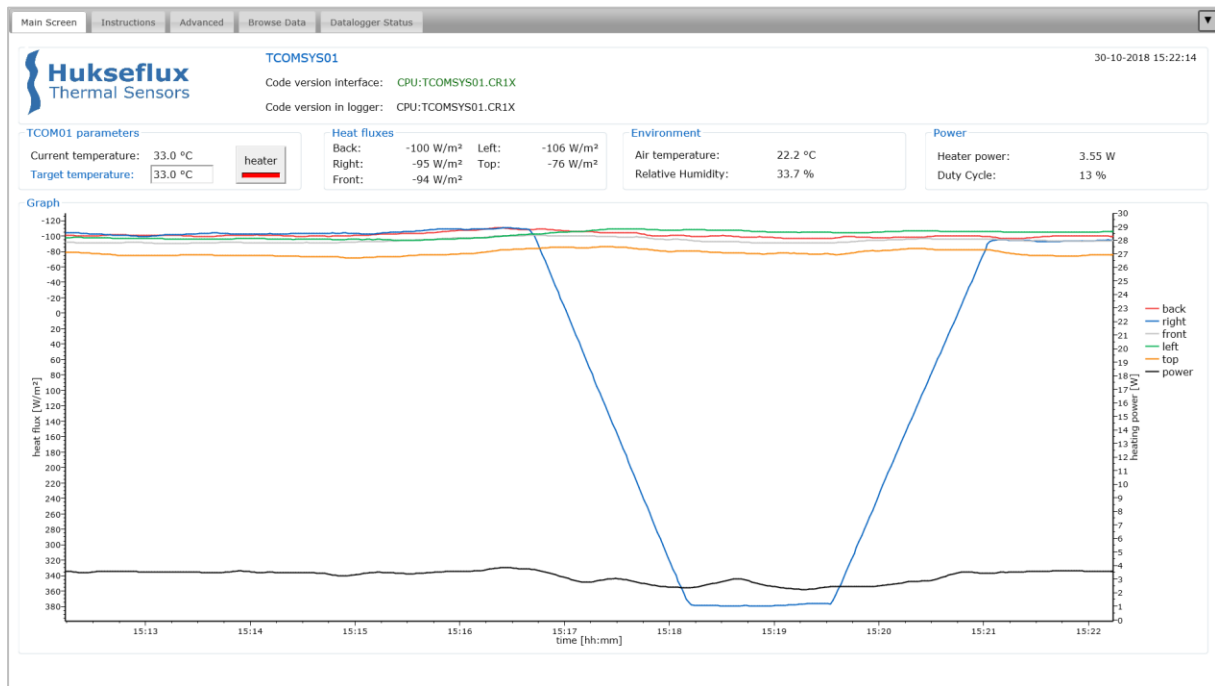

**Figure 6.3.4.1** TCOMSYS01 experiment: shine on one side of the TCOM01 with a lamp. A strong lamp shines on the right side of the TCOM01 for 2.5 minutes. This radiation from the lamp is absorbed by the black foils, creating a radiative asymmetry. The sides of the TCOM01 that are not exposed are not affected.

## 7 Maintenance and trouble shooting

To check the status of the datalogger, look at the 'Datalogger Status' tab of the interface.

For general maintenance on the system, like changing the station time, we recommend to use the Campbell Scientific LoggerLink app, available from <https://www.campbellsci.com/loggerlink>.

Alternatively, you can use Campbell Scientific Device Configuration Utility, available from <https://www.campbellsci.com/devconfig>.

### 7.1 Recommended maintenance and quality assurance

TCOMSYS01 measures reliably at a low level of maintenance. Unreliable measurement results are detected by scientific judgement, for example by looking for unreasonably large or small measured values. The preferred way to obtain a reliable measurement is a regular critical review of the measured data, preferably checking against other measurements.

**Table 7.1.1** *Recommended maintenance of TCOMSYS01*

<b>MINIMUM RECOMMENDED TCOMSYS01 MAINTENANCE</b>			
	INTERVAL	SUBJECT	ACTION
1	every measurement	data analysis	Critically review the data. Look for any patterns and events that deviate from what is normal or expected. Inspect cable quality, inspect mounting.
2	2 years	system check	Perform a full functional check of the system. Preferably, send the system back to the manufacturer for this check.
3		lifetime assessment	Judge if the instrument will be reliable for another 2 years, or if it should be replaced.
4	> 3 years	possible battery replacement	The internal battery in the MCU is rated for a 3 year life with no external power source.  If the battery is exhausted, contact the factory for instructions.

## 7.2 Trouble shooting

**Table 7.2.1** *Trouble shooting for TCOMSYS01 (continued on next page)*

<p>General</p>	<p>Inspect the sensors and MCU for any damage. Check the condition of the cables.</p> <p>Check if the datalogger program is running.</p> <p>Check the CR1000X Station Status for error messages (in the 'Datalogger Status' tab of the interface).</p>
<p>The FHF01 sensors do not give any signal</p>	<p>Check if the sensors react to heat: Expose the sensor to heat, for instance touching it with your hand. Touching the black absorber should show a response on the heat flux sensor.</p> <p>Disconnect cable 1 from the MCU. Check the electrical resistance of the sensor between the connector pins 1 and 6, 2 and 6, 3 and 6, 4 and 6, and 5 and 6. Use a multimeter at the 100 <math>\Omega</math> range. Measure the sensor resistance first with one polarity, then reverse the polarity. Take the average value.</p> <p>Measured resistance should be within the sensor resistance range of 50 to 100 <math>\Omega</math>. Infinite resistance indicates a broken circuit; zero or a low resistance indicates a short circuit.</p>
<p>The heater power does not give any signal</p>	<p>Check the status of the 'Heater' button on the 'Main Screen'. This must be highlighted for the heater to work.</p> <p>Update the measurement of the heater current by pressing the 'Measure heater current' button on the 'Advanced' of the interface.</p> <p>Disconnect cable 2 from the MCU. Check the electrical resistance of the heater between the connector pins 1 and 3 (or alternatively 2 and 4). Use multimeter at the 10 <math>\Omega</math> range. Measure the heater resistance first with one polarity, then reverse the polarity. Take the average value.</p> <p>Measured resistance should be the typical heater resistance of 4 <math>\Omega</math>. Infinite resistance indicates a broken circuit; zero or a low resistance indicates a short circuit. The thermal fuse may be molten.</p>
<p>The body temperature does not give any signal</p>	<p>Disconnect cable 1 from the MCU. Check the electrical resistance of the 10 k<math>\Omega</math> thermistor between the connector pins 7 and 8. Use multimeter at the 100 k<math>\Omega</math> range. Measure the 10 k<math>\Omega</math> thermistor resistance first with one polarity, then reverse the polarity. Take the average value.</p> <p>Measured resistance should be the typical 10 k<math>\Omega</math> thermistor resistance of 10 k<math>\Omega</math>. Infinite resistance indicates a broken circuit; zero or a low resistance indicates a short circuit.</p>
<p>The ambient air temperature and relative humidity do not give any signal</p>	<p>Inspect the humidity module on the MCU for any damage.</p> <p>If problems remain, contact the factory for instructions.</p>
<p>There are doubts about the MCU measurement</p>	<p>Compare measurement results to those with a calibrated multimeter. Short-circuit the input using a 10 <math>\Omega</math> resistor. The heat flux signal should be 0 W/m<sup>2</sup>, the temperature signal should reach 325 °C.</p>

**Table 7.2.1** *Trouble shooting for TCOMSYS01 (started on previous page)*

The sensor signals are unrealistically high or low	Check the cable condition looking for cable breaks. Check the data acquisition by applying a $1 \times 10^{-6}$ V source to it in the $1 \times 10^{-6}$ V range. Look at the measurement result. Check if it is as expected. Check the data acquisition by short circuiting the data acquisition input with a $10 \Omega$ resistor. Look at the output.
The sensor signals show unexpected variations	Check the presence of strong sources of electromagnetic radiation (radar, radio). Check the condition of the sensor cable. Check if the cable is not moving during the measurement.

## 8 Appendices

### 8.1 Advanced settings

On the 'Advanced' tab of the interface, it is possible to fine tune the TCOMSYS01.

NOTE: changing these parameters may cause the TCOMSYS01 measurement to become unstable. The recommended settings are entered as default values.

**Table 8.1.1** *TCOMSYS01 advanced settings (continued on next page)*

Maximum temperature	<p>Software limit on the maximum temperature of the TCOM01 in [°C]. Above this temperature, duty cycle will be set to 0 % automatically.</p> <p>NOTE: TCOM01 has a temperature fuse that limits the temperature to 60 °C. Do not enter a maximum temperature above 60 °C.</p> <p>Default value: 55 °C</p>
Heater calibration interval	<p>Interval at which the heater current draw is measured. Every heater calibration interval, the duty cycle is set to 100 % for 10 scans and the heater current draw is measured and updated</p> <p>Default value: 360 min</p>
Average count	<p>Number of scans that are used to determine the averages of heater power, heat fluxes, TCOM01 body temperature,</p> <p>The time over which the measurements are averages is determined both by the average count and the scan interval</p> <p>Default value: 40 scans</p> <p>The interval at which data is written to the "TcomSysData" table is the &lt;number of scans&gt; x 1500 ms. Default 1 per minute.</p>
P gain factor	<p>The proportional gain of the PID controller</p> <p>Default value: 6.0</p>
I gain factor	<p>The integral gain of the PID controller</p> <p>Default value: 0.2</p>
D gain factor	<p>The differential gain of the PID controller</p> <p>Default value: 0.2</p>
Username	<p>Field to enter an operator name. This name will be written to the 'TcomSysData' table.</p> <p>Field is limited to 40 characters</p>
Comment	<p>Field to enter a comment on your measurement. This comment will be written to the 'TcomSysData' table.</p> <p>Field is limited to 64 characters</p>

**Table 8.1.2** *TCOMSYS01 advanced buttons*

Apply and Reset	Apply any changes in the Constants table. Pressing this button will force a restart of the TCOMSYS01
Measure heater current	Force a measurement of the heater current Duty cycle will be set to 100 % for the specified 'Heater calibration time' and the heater current value will be updated.

**Table 8.1.3** *TCOMSYS01 advanced read only parameters*

Logger temperature	CR1000X panel temperature
Supply voltage	CR1000X supply voltage

## 8.2 Ordering the TCOM01 sensor only

The TCOM01 thermal comfort sensor is also available as a "sensor only".

The configuration includes the mannequin with 5 x heat flux, 1 x temperature, 1 x heater, 2 x cable, 2 x chassis connector and 1 x tripod. The user then must combine it with his own measurement and control unit.

Arriving at the customer, the delivery of TCOM01 should include:

- 1 x HPRC 2300 carrying case
- 1 x TCOM01 thermal comfort sensor
- 1 x 5 pin PHOENIX CONTACT cable, 1.5 m
- 1 x 8 pin PHOENIX CONTACT cable, 1.5 m
- 1 x Manfrotto PIXI EVO 2 tripod
- 1 x Binder M12-A chassis connector 5 pin
- 1 x Binder M12-A chassis connector 8 pin
- 1 x product certificate



**Figure 8.2.1** TCOM01 as "sensor only", supplied with two cables.



To build your own thermal comfort measuring system,

- 1) Measure the resistance of the 10 k $\Omega$  thermistor and convert this to temperature.

To convert the resistance in  $\Omega$  to temperature in  $^{\circ}\text{C}$ , use the Steinhart-Hart equation.

$$T = \frac{1}{\alpha + \beta \ln(R_{\text{thermistor}}) + \gamma \ln(R_{\text{thermistor}})^3} - 273.15 \quad (\text{Formula 8.2.1})$$

with  $R_{\text{thermistor}}$  the thermistor resistance in  $\Omega$ ,  $T$  the temperature in  $^{\circ}\text{C}$ ,  $\alpha$ ,  $\beta$  and  $\gamma$  the Steinhart-Hart coefficients

$$\alpha = 1.1226 \times 10^{-3}$$

$$\beta = 2.3517 \times 10^{-4}$$

$$\gamma = 8.3908 \times 10^{-8}$$

- 2) Measure the voltage output of the 5 heat flux sensors and convert this to heat flux.

To convert the voltage output to heat flux, use

$$\Phi = \frac{U}{S} \quad (\text{Formula 8.2.2})$$

with  $U$  the voltage output in  $\text{V}$ ,  $S$  the sensitivity of the heat flux sensor in  $\text{V}/(\text{W}/\text{m}^2)$  and  $\Phi$  the heat flux in  $\text{W}/\text{m}^2$ .

The sensitivity of the heat flux sensors can be found on the product certificate

- 3) Supply power to the heater.

The heater is specified for a maximum power of 40  $\text{W}$  and has a nominal resistance of 3.6  $\Omega$ . The individual heater resistance can be found on the product certificate. When calculating heater power, account for a cable resistance of 0.6  $\Omega$ . Do not use more than 12  $\text{VDC}$  to power the heater.

Control the heater power to maintain a stable TCOM01 temperature, for example using a PID controller.

Measure the heater power, by measuring the voltage drop over the heater, the current draw of the heater, or both.

Colour coding of the chassis connectors and an example of a measurement circuit are shown below.

**Table 8.2.1** connections Cable 1

PIN	WIRE	
1	white	heat flux top [+]
2	brown	heat flux right [+]
3	green	heat flux front [+]
4	yellow	heat flux left [+]
5	grey	heat flux back [+]
6	pink	heat flux (all) [-]
7	blue	10 k $\Omega$ thermistor [+]
8	red	10 k $\Omega$ thermistor [-]

**Table 8.2.2** connections Cable 2

PIN	WIRE	
1	brown	heater [+]
2	white	heater [+]
3	blue	heater [-]
4	black	heater [-]
5	grey	not connected

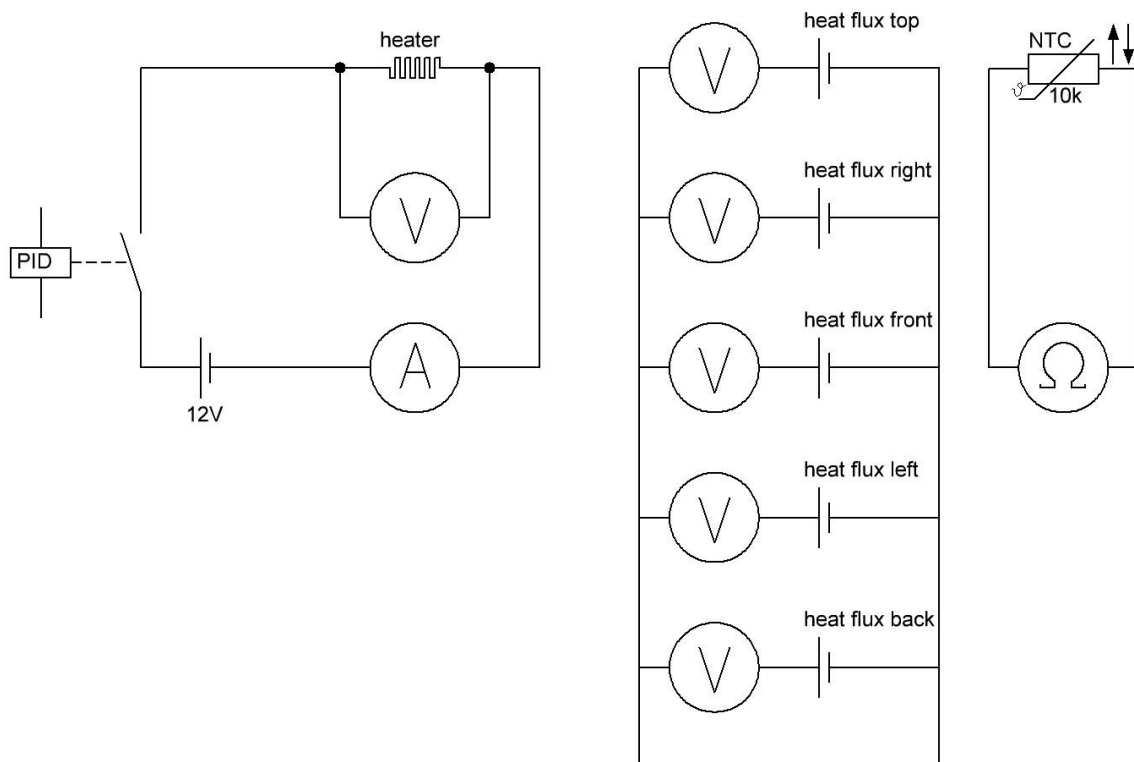

**Figure 8.2.1** Example of a measurement circuit used to build a thermal comfort measuring system with a TCOM01 thermal comfort sensor.

### 8.3 EU declaration of conformity TCOMSYS01



We, Hukseflux Thermal Sensors B.V.  
Delftechpark 31  
2628 XJ Delft  
The Netherlands

in accordance with the requirements of the following directive:

2006/95/EG	The Low Voltage Directive
2011/65/EU	The Restriction of Hazardous Substances Directive
2014/30/EU	The Electromagnetic Compatibility Directive

hereby declare under our sole responsibility that:

Product model: TCOMSYS01  
Product type: Thermal comfort measuring system

has been designed to comply and is in conformity with the relevant sections and applicable requirements of the following standards:

Emission:	IEC/EN 61000-6-1, Class B, RF emission requirements (toughest), IEC CISPR11 and EN 55011 Class B requirements
Immunity:	IEC/EN 61000-6-2 (toughest) and IEC 61326 requirement
Report:	"Hukseflux Tcomsys01_b.pdf", 21 November 2018



Eric HOEKSEMA  
Director  
Delft  
November 23, 2018

## 8.4 EU declaration of conformity TCOM01



We, Hukseflux Thermal Sensors B.V.  
Delftechpark 31  
2628 XJ Delft  
The Netherlands

in accordance with the requirements of the following directive:

2011/65/EU The Restriction of Hazardous Substances Directive  
2014/30/EU The Electromagnetic Compatibility Directive

hereby declare under our sole responsibility that:

Product model: TCOM01  
Product type: Thermal comfort sensor

has been designed to comply and is in conformity with the relevant sections and applicable requirements of the following standards:

Emission: IEC/EN 61000-6-1, Class B, RF emission requirements (toughest), IEC  
CISPR11 and EN 55011 Class B requirements  
Immunity: IEC/EN 61000-6-2 (toughest) and IEC 61326 requirement  
Report: "Hukseflux Tcomsys01\_b.pdf", 21 November 2018

NOTE: TCOM01 has been tested in a specific system configuration



Eric HOEKSEMA  
Director  
Delft  
November 23, 2018

