

USER MANUAL SRA01

Second class albedometer



Warning statements



Putting more than 12 Volt across the sensor wiring can lead to permanent damage to the sensor.



Do not use "open circuit detection" when measuring the sensor outputs.

Contents

Warning statements	2
Contents	3
List of symbols	4
Introduction	5
1 Ordering and checking at delivery	7
1.1 Ordering SRA01	7
1.2 Included items	7
1.3 Quick instrument check	7
2 Instrument principle and theory	8
3 Specifications of SRA01	11
3.1 Specifications of SRA01 albedometer	11
3.2 Specifications of SR01 pyranometer	13
3.3 Dimensions of SRA01	15
4 Standards and recommended practices for use	16
4.1 Classification standard	16
4.2 General use for solar radiation measurement	16
4.3 General use for sunshine duration measurement	16
4.4 Specific use in meteorology and climatology	17
5 Installation of SRA01	18
5.1 Site selection and installation	18
5.2 Electrical connection	19
5.3 Requirements for data acquisition / amplification	20
6 Maintenance and trouble shooting	21
6.1 Recommended maintenance and quality assurance	21
6.2 Trouble shooting	22
6.3 Calibration and checks in the field	23
6.4 Data quality assurance	24
7 Appendices	26
7.1 Appendix on cable extension / replacement	26
7.2 Appendix on tools for SRA01	27
7.3 Appendix on spare parts for SRA01	27
7.4 Appendix on standards for classification and calibration	28
7.5 Appendix on calibration hierarchy	29
7.6 Appendix on meteorological radiation quantities	30
7.7 Appendix on ISO and WMO classification tables	31
7.8 Appendix on definition of pyranometer specifications	32
7.9 Appendix on terminology / glossary	33
7.10 EC declaration of conformity	34

List of symbols

Quantities

	Symbol	Unit
Voltage output	U	V
Sensitivity	S	V/(W/m ²)
Solar irradiance	E	W/m ²

(see also appendix 7.6 on meteorological quantities)

Subscripts

Measuring downwelling radiation	↓
Measuring upwelling radiation	↑

Introduction

SRA01 albedometer is an instrument that measures global and reflected solar radiation and the solar albedo, or solar reflectance. It is composed of two identical second class pyranometers with thermopile sensors, the upfacing one measuring global solar radiation, the downfacing one measuring reflected solar radiation. SRA01 complies with the latest ISO and WMO standards.

Albedo, also called solar reflectance, is defined as the ratio of the reflected to the global radiation. The solar albedo depends on the directional distribution of incoming radiation and on surface properties at ground level. Albedos of typical surfaces range from about 4 % for fresh asphalt, and 15 % for green grass to 90 % for fresh snow.

Using SRA01 is easy. The upfacing pyranometer measures global solar radiation, the downfacing pyranometer measures reflected solar radiation. The irradiance in W/m^2 in each direction is calculated by dividing the pyranometer output, a small voltage, by the sensitivity. The sensitivity of both pyranometers, model SR01, is provided on the SRA01 product certificate.

The central equation governing both pyranometers of SRA01 is:

$$E = U/S \quad \text{(Formula 0.1)}$$

SRA01 can be connected directly to commonly used datalogging systems.

The instrument should be used in accordance with the recommended practices of ISO, WMO and ASTM.



Figure 0.1 SRA01 second class albedometer, displayed from different sides

The albedo is calculated by dividing the reflected radiation by the global radiation. The following equations apply. For terminology: see also the appendix on meteorological radiation quantities.

Upfacing and downfacing pyranometers, global and reflected solar radiation:

$$E_{g \downarrow h} = U/S \quad (\text{Formula 0.2})$$

$$E_{r \uparrow} = U/S \quad (\text{Formula 0.3})$$

Net solar radiation and albedo:

$$E_{g^*} = E_{g \downarrow h} - E_{r \uparrow} \quad (\text{Formula 0.4})$$

$$\text{Albedo} = E_{r \uparrow} / E_{g \downarrow h} \quad (\text{Formula 0.5})$$

WMO has approved the “pyranometric method” to calculate sunshine duration from pyranometer measurements in WMO-No. 8, Guide to Meteorological Instruments and Methods of Observation. This implies that the upfacing SR01 pyranometer may be used, in combination with appropriate software, to estimate sunshine duration. This is much more cost-effective than using a dedicated sunshine duration sensor. Ask for our application note.

Albedometers are used for general meteorological observations, building physics, roof reflectance studies, climate studies and solar collector testing. A common application is for outdoor solar radiation measurements as part of a meteorological station. This application requires horizontal levelling; a bubble level and a levelling assembly for one axis are included. SRA01 is made to fit a ¾ inch NPS mounting tube.



Figure 0.2 SRA01 mounted on a tube

1 Ordering and checking at delivery

1.1 Ordering SRA01

The standard configuration of SRA01 is with 5 metres cable.

Common options are:

- longer cable (in multiples of 5 m). Specify total cable length.
- sun screens for up- and downfacing pyranometers. Specify order number SCR01 (one sun screen).

1.2 Included items

Arriving at the customer, the delivery should include:

- albedometer SRA01
- cable of the length as ordered
- any other option as ordered
- product certificate matching the instrument serial number

Please store the certificate in a safe place.

1.3 Quick instrument check

General checks:

1. Inspect the instrument for any damage.
2. inspect the bubble level
3. check the instrument serial numbers against the certificates supplied with the instrument.

A quick test of both pyranometers can be done by using a simple hand held multimeter and a lamp.

4. Check the electrical resistance of the pyranometers between the positive (+) and negative (-) wire. Use a multimeter at the 200 Ω range. Measure the sensor resistance first with one polarity, than reverse the polarity. Take the average value. The typical resistance of the wiring is 0.1 Ω /m. Typical resistance should be the typical sensor resistance of 40 to 60 Ω plus 1.5 Ω for the total resistance of two wires (back and forth) of each 5 m. Infinite resistance indicates a broken circuit; zero or a low resistance indicates a short circuit.
5. Check if the sensors react to light: put the multimeter at its most sensitive range of DC voltage measurement, typically the 100 x 10⁻³ VDC range or lower. Expose the sensor to a strong light source, for instance a 100 W light bulb at 0.1 m distance. The signal should read > 2 x 10⁻³ V now. Darken the sensor either by putting something over it or switching off the light. The instrument voltage output should go down and within one minute approach 0 V.

2 Instrument principle and theory

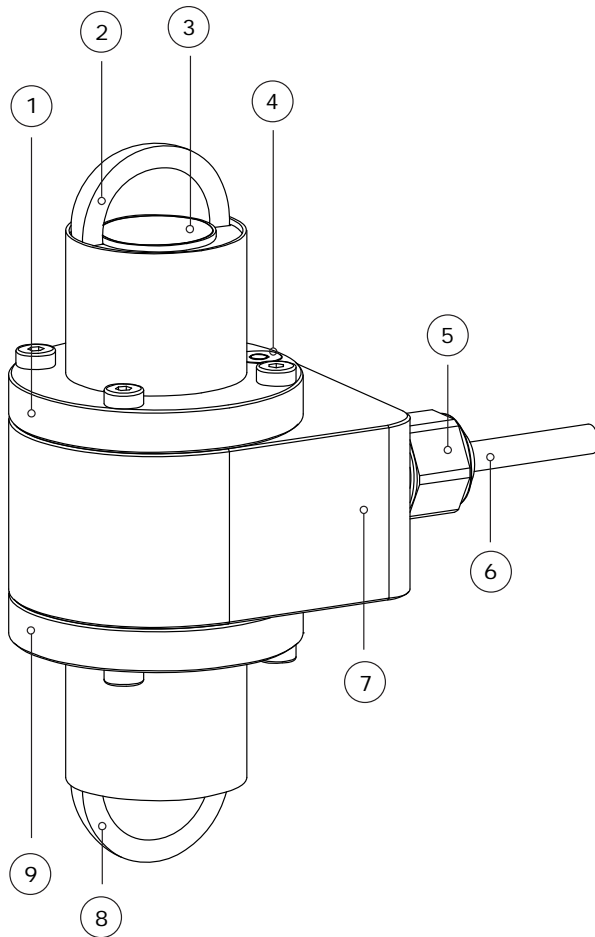

Figure 2.1 overview of SRA01:
(1) upfacing pyranometer body
(2) glass dome
(3) thermal sensor with black coating
(4) bubble level
(5) cable gland
(6) cable
(7) albedometer body
(8) glass dome
(9) downfacing pyranometer body

SRA01's scientific name is albedometer. The albedometer consists of two model SR01 pyranometers, mounted back to back. A pyranometer measures the solar radiation received by a plane surface from a 180 ° field of view angle. This quantity, expressed in W/m^2 , is called "hemispherical" solar radiation.

In general, SRA01 is mounted horizontally. Measuring in the horizontal plane, downward solar radiation is called global solar radiation, upward solar radiation is called reflected solar radiation. The solar radiation spectrum extends roughly from 285 to 3000 $\times 10^{-9}$ m. By definition a pyranometer should cover that spectral range with a spectral selectivity that is as "flat" as possible.

In an irradiance measurement by definition the response to "beam" radiation varies with the cosine of the angle of incidence; i.e. it should have full response when the solar radiation hits the sensor perpendicularly (normal to the surface, sun at zenith, 0 ° angle of incidence), zero response when the sun is at the horizon (90 ° angle of incidence, 90 ° zenith angle), and 50 % of full response at 60 ° angle of incidence.

A pyranometer should have a so-called "directional response" (older documents mention "cosine response") that is as close as possible to the ideal cosine characteristic.

In order to attain the proper directional and spectral characteristics, a pyranometer's main components are:

- a thermal sensor with black coating. It has a flat spectrum covering the 200 to 50000 $\times 10^{-9}$ m range, and has a near-perfect directional response. The coating absorbs all solar radiation and, at the moment of absorption, converts it to heat. The heat flows through the sensor to the sensor body. The thermopile sensor generates a voltage output signal that is proportional to the solar irradiance.
- a glass dome. This dome limits the spectral range from 285 to 3000 $\times 10^{-9}$ m (cutting off the part above 3000 $\times 10^{-9}$ m), while preserving the 180 ° field of view angle. Another function of the dome is that it shields the thermopile sensor from the environment (convection, rain).

Pyranometers can be manufactured to different specifications and with different levels of verification and characterisation during production. The ISO 9060 - 1990 standard, "Solar energy - specification and classification of instruments for measuring hemispherical solar and direct solar radiation", distinguishes between 3 classes; secondary standard (highest accuracy), first class (second highest accuracy) and second class (third highest accuracy). SR01 is a second class pyranometer.

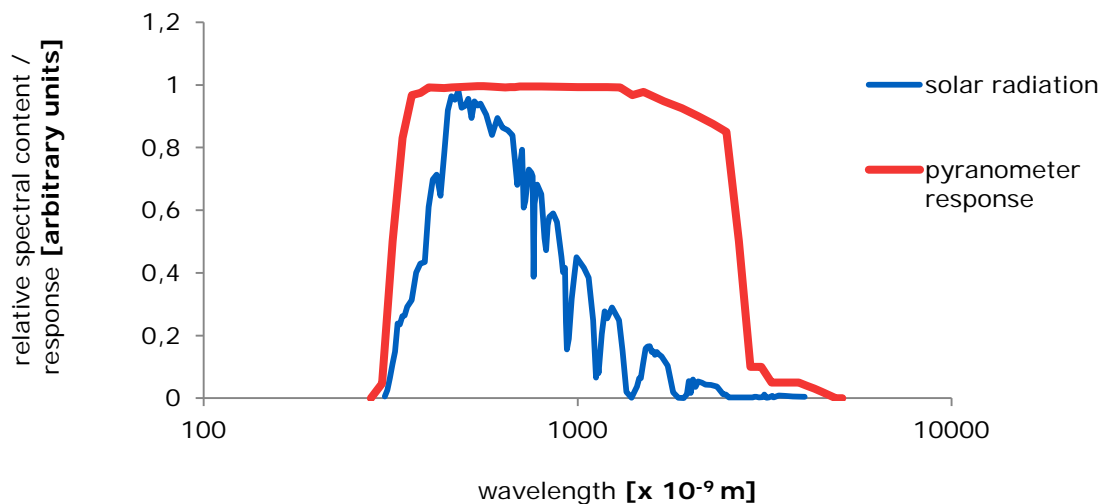

Figure 2.2 Spectral response of the pyranometer compared to the solar spectrum. The pyranometer only cuts off a negligible part of the total solar spectrum.

The uncertainty of a measurement under outdoor conditions depends on many factors. Guidelines for uncertainty evaluation according to the “Guide to Expression of Uncertainty in Measurement” (GUM) can be found in our manuals. We provide spreadsheets to assist in the process of uncertainty evaluation of your measurement. It is important to realise that the uncertainty of the measurement is not only determined by the instrument but also by the way it is used. See also ISO 9060 note 5. In case of pyranometers the measurement uncertainty as obtained during outdoor measurements is a function of:

- the instrument class (applicable to pyranometers)
- the calibration procedure / uncertainty
- the duration of instrument employment under natural sunlight (involving the instrument stability specification)
- the measurement conditions (such as tilting, ventilation, shading, instrument temperature)
- maintenance (mainly fouling)
- the environmental conditions* (such as temperature, position of the sun, presence of clouds, horizon, representativeness of the location). For pyrgeometers, this also involves the presence of natural sunlight which produces a solar offset)

Therefore statements about the overall measurement uncertainty under outdoor conditions can only be made on an individual basis, taking all these factors into account.

* defined at Hukseflux as all factors outside the instrument that are relevant to the measurement such as the cloud cover (presence or absence of direct radiation), sun position, the local horizon (which may be obstructed) or condition of the ground (when tilted). The environmental conditions also involve the question whether or not the measurement at the location of measurement is representative of the quantity that should be measured.

3 Specifications of SRA01

3.1 Specifications of SRA01 albedometer

SRA01 albedometer is an instrument that measures global and reflected solar radiation, the solar albedo, or solar reflectance, and net solar radiation. It is composed of two second class pyranometers with thermopile sensors, mounted back to back, the upper one measuring global radiation, the lower one measuring reflected solar radiation. Working completely passive, using a thermopile sensor, the sensors generate a small output voltage proportional to these fluxes. An optional measurand is sunshine duration.

SRA01 can only be used in combination with a suitable measuring system. It complies with the latest ISO and WMO standards and should be used in accordance with the recommended practices of ISO, IEC, WMO and ASTM.

Table 3.1.1 *Specifications of SRA01 (continued on next pages)*

SRA01 GENERAL SPECIFICATIONS	
Product type	albedometer
Included sensors	2 x identical ISO 9060 second class pyranometer model SR01 (see separate specification table)
Spectral range	285 to 3000 x 10 ⁻⁹ m
Required sensor power	zero (passive sensor)
Rated operating temperature range	-40 to +80 °C
Rated operating relative humidity range	0 to 100 %
Required readout	2 x differential voltage channel or 2 x single ended voltage channel, input resistance > 10 ⁶ Ω
Standards governing use of the instrument	ISO/TR 9901:1990 Solar energy -- Field pyranometers -- Recommended practice for use ASTM G183 - 05 Standard Practice for Field Use of Pyranometers, Pyrhemimeters and UV Radiometers WMO-No. 8, Guide to Meteorological Instruments and Methods of Observation, seventh edition 2008, paragraph 7.3 "measurement of global and diffuse solar radiation", 7.3.3.4 "installation of pyranometers for measuring reflected solar radiation"
SRA01 MEASURANDS	
Measurand upfacing pyranometer	global solar radiation
Measurand in SI units	irradiance in W/m ²
Measurement function / required programming global solar irradiance	$E_g \downarrow_h = U/S$
Measurand downfacing pyranometer	reflected solar radiation
Measurand in SI units	irradiance in W/m ²
Measurement function / required programming reflected solar irradiance	$E_r \uparrow = U/S$
Optional measurand	albedo or solar reflectance
Optional measurand in SI units	albedo or solar reflectance in (W/m ²)/(W/m ²)
Measurement function / required programming albedo	albedo = solar reflectance = $E_r \uparrow / E_g \downarrow_h$
Expected measurement interval of albedo	from about 4 % for fresh asphalt, and 15 % for green grass to 90 % for fresh snow

Table 3.1.1 Specifications of SRA01 (started on previous page)

Optional measurand upfacing pyranometer	sunshine duration
Optional measurand in SI units	sunshine duration in h
Measurement function / optional programming sunshine duration	programming according to WMO guide paragraph 8.2.2
Optional measurand	net solar radiation
Optional measurand in SI units	irradiance in W/m ²
Measurement function / required programming net solar radiation	$E_g^* = E_g \downarrow_h - E_r \uparrow$
SRA01 MOUNTING, CABLING, TRANSPORT	
Standard cable length (see options)	5 m
Cable diameter	5.3×10^{-3} m
Cable replacement	cable can be removed and installed by the user provided that the cable is sealed at the instrument side against humidity ingress. Consult Hukseflux for instructions or use Hukseflux-supplied parts.
Instrument mounting	preferable mounting is on a pipe size ¾ inch NPS. The pipe internally carries the SRA01 signal wire. Internal diameter of the mounting hole is 28.7 mm. Recommended is a ¾ inch NPS tube with an outer diameter < 28 mm and an inner diameter > 20 mm. Attachment with a hex key size 3.0 mm. A levelling assembly for one axis is included. WMO-No. 8, Guide to Meteorological Instruments and Methods of Observation, seventh edition 2008, paragraph 7.3.3.4 "installation of pyranometers for measuring reflected solar radiation" recommends a height of 1 to 2 m above the soil surface.
Levelling	Bubble level and a levelling assembly for one axis are included
Levelling accuracy	< 0.6 ° bubble entirely in ring
IP protection class	IP67
Gross weight including 5 m cable	0.75 kg
Net weight including 5 m cable	1.1 kg
Packaging	box of (170 x 90 x 230) mm
CALIBRATION	
Calibration traceability solar	to WRR (see SR01 for details)
Validity of calibration	based on experience the instrument sensitivity will not change during storage. During use under exposure to solar radiation the instrument "non-stability" specification is applicable.
Recommended recalibration interval	2 years
MEASUREMENT ACCURACY	
Uncertainty of the measurement	statements about the overall measurement uncertainty can only be made on an individual basis. See the chapter on uncertainty evaluation
VERSIONS / OPTIONS	
longer cable, in multiples of 5 m, cable lengths above 20 m in multiples of 10 m	option code = total cable length
ACCESSORIES	
sun screens for up- and downfacing pyranometers	SCR01 (one sun screen)

3.2 Specifications of SR01 pyranometer

SR01 pyranometer measures the solar radiation received by a plane surface from a from a 180 ° field of view angle. This quantity, expressed in W/m^2 , is called “hemispherical” solar radiation. SRA01, in which 2 x SR01 are incorporated, is typically mounted horizontally. Measuring in the horizontal plane, downward solar radiation is called global solar radiation, upward solar radiation is called reflected solar radiation. Working completely passive, using a thermopile sensor, SR01 generates a small output voltage proportional to this flux.

It can only be used in combination with a suitable measurement system. The instrument is classified according to ISO 9060 and should be used in accordance with the recommended practices of ISO, IEC, WMO and ASTM.

Table 3.2.1 *Specifications of SR01 pyranometer (continued on next page)*

SR01 PYRANOMETER MEASUREMENT SPECIFICATIONS: LIST OF CLASSIFICATION CRITERIA OF ISO 9060*	
ISO classification (ISO 9060: 1990)	second class pyranometer
WMO performance level (WMO-No-8, seventh edition 2008)	moderate quality pyranometer
Response time (95 %)	18 s
Zero offset a (response to 200 W/m^2 net thermal radiation)	$< \pm 15 W/m^2$ unventilated
Zero offset b (response to 5 K/h change in ambient temperature)	$< \pm 4 W/m^2$
Non-stability	$< \pm 1 \%$ change per year
Non-Linearity	$< \pm 1 \%$ (100 to 1000 W/m^2)
Directional response	$< \pm 25 W/m^2$
Spectral selectivity	$< \pm 5 \%$ (0.35 to $1.5 \times 10^{-6} m$)
Temperature response	$< \pm 3 \%$ (-10 to +40 °C)
Tilt response	$< \pm 2 \%$ (0 to 90 ° at 1000 W/m^2)

*For the exact definition of pyranometer ISO 9060 specifications see the appendix.

Table 3.2.1 *Specifications of SR01 pyranometer (continued)*

SR01 PYRANOMETER ADDITIONAL SPECIFICATIONS	
Measurand	global and reflected solar radiation
Measurand in SI radiometry units	irradiance in W/m^2
Field of view angle	180 °
Measurement range	0 to 2000 W/m^2
Sensitivity range	7 to 25 $\times 10^{-6} V/(W/m^2)$
Sensitivity (nominal)	15 $\times 10^{-6} V/(W/m^2)$
Expected voltage output	application under natural solar radiation: -0.1 to + 50 $\times 10^{-6} V$
Measurement function / required programming	$E = U/S$
Sensor resistance range	40 to 60 Ω
Required sensor power	zero (passive sensor)
Spectral range (20 % transmission points)	285 to 3000 $\times 10^{-9} m$
CALIBRATION	
Calibration traceability	to WRR
Calibration hierarchy	from WRR through ISO 9846 and ISO 9847, applying a correction to reference conditions
Calibration method	indoor calibration according to ISO 9847, Type IIc
Calibration uncertainty	< 1.8 % ($k = 2$)
Reference conditions	20 °C, normal incidence solar radiation, horizontal mounting, irradiance level 1000 W/m^2
MEASUREMENT ACCURACY	
Uncertainty of the measurement	statements about the overall measurement uncertainty can only be made on an individual basis. See the chapter on uncertainty evaluation
Global horizontal irradiance: WMO estimate on achievable accuracy for daily sums (see appendix for a definition of the measurement conditions)	$\pm 10 \%$
Global horizontal irradiance: WMO estimate on achievable accuracy for hourly sums (see appendix for a definition of the measurement conditions)	$\pm 20 \%$

3.3 Dimensions of SRA01

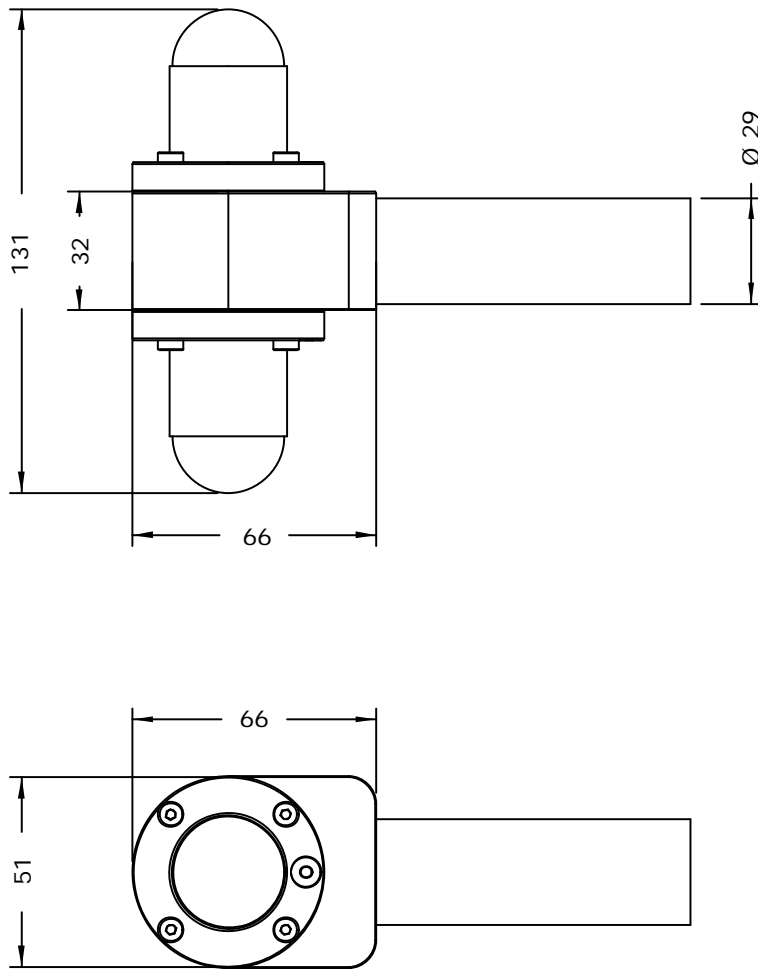

Figure 3.2.1 Dimensions of SRA01 in 10^{-3} m.

4 Standards and recommended practices for use

Pyranometers are classified according to the ISO 9060 standard and the WMO-No. 8 Guide. In any application the instrument should be used in accordance with the recommended practices of ISO, IEC, WMO and / or ASTM.

4.1 Classification standard

Table 4.1.1 Standards for pyranometer classification. See the appendix for definitions of pyranometer specifications, and a table listing the specification limits.

STANDARDS FOR INSTRUMENT CLASSIFICATION		
ISO STANDARD	EQUIVALENT ASTM STANDARD	WMO
ISO 9060:1990 Solar energy -- specification and classification of instruments for measuring hemispherical solar and direct solar radiation	Not available	WMO-No. 8; Guide to Meteorological Instruments and Methods of Observation, chapter 7, measurement of radiation, 7.3 measurement of global and diffuse solar radiation

4.2 General use for solar radiation measurement

Table 4.2.1 Standards with recommendations for instrument use in solar radiation measurement

STANDARDS FOR INSTRUMENT USE FOR HEMISPHERICAL SOLAR RADIATION		
ISO STANDARD	EQUIVALENT ASTM STANDARD	WMO
ISO/TR 9901:1990 Solar energy -- Field pyranometers -- Recommended practice for use	ASTM G183 - 05 Standard Practice for Field Use of Pyranometers, Pyrhemimeters and UV Radiometers	WMO-No. 8; Guide to Meteorological Instruments and Methods of Observation, chapter 7, measurement of radiation, 7.3 measurement of global and diffuse solar radiation

4.3 General use for sunshine duration measurement

According to the World Meteorological Organization (WMO, 2003), sunshine duration during a given period is defined as the sum of that sub-period for which the direct solar irradiance exceeds 120 W/m².

WMO has approved the “pyranometric method” to estimate sunshine duration from pyranometer measurements (Chapter 8 of the WMO Guide to Instruments and Observation, 2008). This implies that a pyranometer may be used, in combination with appropriate software, to estimate sunshine duration. Ask for our application note.

Table 4.3.1 *Standards with recommendations for instrument use in sunshine duration measurement*

STANDARDS FOR INSTRUMENT USE FOR SUNSHINE DURATION

WMO

WMO-No. 8; Guide to Meteorological Instruments and Methods of Observation, chapter 8, measurement of sunshine duration, 8.2.2 Pyranometric Method

4.4 Specific use in meteorology and climatology

The World Meteorological Organization (WMO) is a specialised agency of the United Nations. It is the UN system’s authoritative voice on the state and behaviour of the earth’s atmosphere and climate. WMO publishes WMO-No. 8; Guide to Meteorological Instruments and Methods of Observation, in which a table is included on “level of performance” of pyranometers. Nowadays WMO conforms itself to the ISO classification system.

5 Installation of SRA01

5.1 Site selection and installation

Table 5.1.1 Recommendations for installation of SRA01

Location	the horizon should be as free from obstacles as possible. Ideally there should be no objects between the course of the sun and the instrument. The soil surface should be representative of the area under observation.
Mechanical mounting / thermal insulation	SRA01 is suitable for mounting on a ¾ inch NPS tube. The SRA01 cable is led through the tube. Recommended is a ¾ inch NPS tube with an outer diameter < 28 mm and an inner diameter > 20 mm. A levelling assembly for one axis is included. Fixation is done using a 3 mm hex key. Do not mount the instrument on objects that become very hot (black coated metal plates).
Levelling	Use the bubble level on the instrument. The instrument may be rotated around the axis of the arm on which it is mounted. The arm itself may be tilted to attain a perfectly level position.
Instrument orientation	by convention with the cable exit pointing to the nearest pole (so the cable exit should point north in the northern hemisphere, south in the southern hemisphere).
Installation height	WMO recommends a distance of 1.5 to 2 m between soil surface and downfacing sensors (reducing the effect of shadows and in order to obtain good spatial averaging).

5.2 Installation of the optional sun screens

As an option, SCR01 sun screen(s) may be added to the up- and/or downfacing pyranometers of SRA01 albedometer. The SCR01 sun screen can be installed and removed using a hex key (size 2 mm). See the drawing below.



Figure 5.2.1 SCR01 sun screen and its installation and removal: turn the set screw using the hex key and lift off the sun screen to remove. (1) hex key, (2) sun screen, (3) set screw

5.3 Electrical connection

In order to operate, the 2 x SR01 pyranometer in SRA01 should both be connected to a measurement system, typically a so-called datalogger. SR01's are passive sensors that do not need any power.

Table 5.3.1 *The electrical connection of the SRA01.*

PIN	WIRE	CONNECTION
1	Blue	SR01 ↓ [-]
2	Red	SR01 ↓ [+]
3	Yellow	not connected
4	Brown	not connected
5	Grey	not connected
6	Pink	not connected
7	Green	SR01 ↑ [-]
8	White	SR01 ↑ [+]
11	Black	shield

Cables generally act as a source of distortion, by picking up capacitive noise. We recommend keeping the distance between a datalogger or amplifier and the sensor as short as possible. For cable extension, see the appendix on this subject.

5.4 Requirements for data acquisition / amplification

The selection and programming of dataloggers is the responsibility of the user. Please contact the supplier of the data acquisition and amplification equipment to see if directions for use with the SRA01 are available.

In case programming for similar instruments is available, this can in general also be used. SRA01 can usually be treated as two single thermopile pyranometers. Pyranometers usually have the same programming as heat flux sensors.

Table 5.4.1 *Requirements for data acquisition and amplification equipment for SRA01 in the standard configuration*

Voltage measurement uncertainty requirements	2 input channels Recommended: $< \pm 5 \times 10^{-6} \text{ V}$ Accepted: $< \pm 20 \times 10^{-6} \text{ V}$ (valid for the entire expected temperature range of the acquisition / amplification equipment) NOTE: a $15 \times 10^{-6} \text{ V}$ uncertainty translates to 1 W/m^2 NOTE: some sources of uncertainty cancel when measuring the net-radiation
Capability for the data logger or the software	to store data, and to perform division by the sensitivity to calculate the solar irradiance and other optional measurands.
Voltage measurement input resistance	$> 1 \times 10^6 \Omega$
Open circuit detection (WARNING)	open-circuit detection should not be used, unless this is done separately from the normal measurement by more than 5 times the sensor response time and with a small current only. Thermopile sensors are sensitive to the current that is used during open circuit detection. The current will generate heat, which is measured and will appear as an offset.

6 Maintenance and trouble shooting

6.1 Recommended maintenance and quality assurance

SRA01 can measure reliably at a low level of maintenance in most locations. Usually unreliable measurements will be detected as unreasonably large or small measured values. As a general rule this means that regular visual inspection combined with a critical review of the measured data, preferably checking against other measurements, is the preferred way to obtain a reliable measurement.

Table 6.1.1 *Recommended maintenance of SRA01. If possible the data analysis and cleaning (1 and 2) should be done on a daily basis.*

MINIMUM RECOMMENDED PYRANOMETER MAINTENANCE			
	INTERVAL	SUBJECT	ACTION
1	1 week	data analysis	compare measured data to maximum possible / maximum expected irradiance and to other measurements nearby (redundant instruments). Analyse patterns in albedo. Also historical seasonal records can be used as a source for expected values. Analyse night time signals. These signals may be negative (down to -5 W/m^2 on clear windless nights), due to zero offset a. In case of use with PV systems, compare daytime measurements to PV system output. Look for any patterns and events that deviate from what is normal or expected.
2	2 weeks	cleaning	use a soft cloth to clean the dome of the instrument, persistent stains can be treated with soapy water or alcohol
3	6 months	inspection	inspect cable quality, inspect cable glands, inspect mounting position, inspect cable, clean instrument, clean cable, inspect levelling, change instrument tilt in case this is out of specification, inspect mounting connection, inspect interior of dome for condensation
4	2 years	recalibration	recalibration by side-by-side comparison to a higher standard instrument in the field according to ISO 9847
5		lifetime assessment	judge if the instrument should be reliable for another 2 years, or if it should be replaced
6	6 years	parts replacement	if applicable / necessary replace the parts that are most exposed to weathering; cable, cable gland, sun screen. NOTE: use Hukseflux approved parts only.
7		internal inspection	if applicable: open instrument and inspect / replace O-rings; dry internal cavity around the circuit board
8		recalibration	recalibration by side-by-side comparison to a higher standard instrument indoors according to ISO 9847 or outdoors according to ISO9846

6.2 Trouble shooting

For checking the instrument see the wiring diagram on the product certificate or in chapter 5 of this manual.

Table 6.2.1 *Trouble shooting for SR01/SRA01*

The sensor does not give any signal	<p>Check the electrical resistance of the sensor between the (-) and (+) wire of the pyranometer. Use a multimeter at the 200 Ω range. Measure the sensor resistance first with one polarity, than reverse the polarity. Take the average value. The typical resistance of the wiring is 0.1 Ω/m. Typical resistance should be the typical sensor resistance of 40 to 60 Ω plus 1.5 Ω for the total resistance of two wires (back and forth) of each 5 m. Infinite resistance indicates a broken circuit; zero or a low resistance indicates a short circuit. Check if the sensor reacts to light: put the multimeter at its most sensitive range of DC voltage measurement, typically the 100 x 10⁻³ VDC range or lower. Expose the sensor to strong light source, for instance a 100 W light bulb at 1 x 10⁻¹ m distance. The signal should read > 2 x 10⁻³ V now. Darken the sensor either by putting something over it or switching off the light. The instrument voltage output should go down and within one minute approach 0 V. Check the data acquisition by applying a 1 x 10⁻⁶ V source to it in the 1 x 10⁻⁶ V range.</p>
The sensor signal is unrealistically high or low	<p>Note that night-time signals of upfacing pyranometers may be negative (down to - 5 W/m² on clear windless nights), due to zero offset a. Check if the pyranometer has clean domes. Check the location of the pyranometer; are there any obstructions that could explain the measurement result. Check the orientation / levelling of the pyranometer. Check if the right calibration factor is entered into the algorithm. Please note that each sensor has its own individual calibration factor, as documented in its calibration certificate. Check if the voltage reading is divided by the calibration factor in review of the algorithm. Check the condition of the wiring at the logger. Check the cable condition looking for cable breaks. Check the range of the data logger; signal can be negative (this could be out of range) or the amplitude could be out of range. Check the data acquisition by applying a 1 x 10⁻⁶ V source to it in the 1 x 10⁻⁶ V range. Look at the output. Check if the output is as expected. Check the data acquisition by short circuiting the data acquisition input with a 100 Ω resistor. Look at the output. Check if the output is close to 0 W/m².</p>
The sensor signal shows unexpected variations	<p>Check the presence of strong sources of electromagnetic radiation (radar, radio etc.) Check the condition of the shielding. Check the condition of the sensor cable. Check if the cable is not moving during the measurement</p>
The sensor signal is unrealistically high or low	<p>Check the electrical resistance between the sensor wires of different sensors; this should be higher than 1 x 10⁶ Ω. Most multimeters cannot measure in this range, so please use the highest range. Check between the two different sensors and between sensors and body.</p>
The dome shows internal condensation	<p>Arrange to send the sensor back to Hukseflux for diagnosis.</p>

When trouble shooting, inspect the instrument and cables for any damage and check the instrument serial numbers against the certificates supplied with the instrument.

If the trouble shooting steps were followed and further diagnosis is needed, contact Hukseflux and arrange to send an Excel file containing raw sensor data of a few days of measurement for diagnostics. Include time of day, coordinates, raw voltages and instrument temperature.

6.3 Calibration and checks in the field

A check or calibration of an albedometer consists of 2 pyranometer calibrations.

6.3.1 Albedometer inversion test

Hukseflux recommends to perform a so-called instrument-inversion-test after installation. This test consists of inverting the instrument orientation (180 ° turn around the mounting tube), and looking at the output signals. For testing pyranometers, perform this test on a clear day, preferably under around noon (with the sun high in the sky). It is assumed both downwelling and upwelling radiation are the same as measured prior to the test within a time interval of several minutes. For this crude test, deviations within $\pm 10\%$ or 10 W/m^2 (choose the largest value) between U/S readings of individual sensors may pass as acceptable.

6.3.2 Calibration and checks for pyranometers

Recalibration of field pyranometers is typically done by comparison in the field to a reference pyranometer. The applicable standard is ISO 9847 "International Standard-Solar Energy- calibration of field pyranometers by comparison to a reference pyranometer". At Hukseflux an indoor calibration according to the same standard is used.

Hukseflux recommendation for re-calibration: if possible, perform calibration indoor by comparison to an identical reference instrument, under normal incidence conditions.

In case of field comparison; ISO recommends field calibration to a higher class pyranometer. Hukseflux suggests also allowing use of sensors of the same model and class, because intercomparisons of similar instruments has the advantage that they suffer from the same offsets. It is therefore just as good to compare to pyranometers of the same brand and type as to compare to an instrument of a higher class. ISO recommends to perform field calibration during several days; 2 to 3 days under cloudless conditions, 10 days under cloudy conditions. In general this is not achievable. In order to shorten the calibration process Hukseflux suggests to allow calibration at normal incidence, using hourly totals near solar noon.

Hukseflux main recommendations for field intercomparisons are:

- 1) to take normal incidence as a reference and not the entire day.
- 2) to take a reference of the same brand and type as the field pyranometer or a pyranometer of a higher class, and
- 3) to connect both to the same electronics, so that electronics errors (also offsets) are eliminated.
- 4) to mount all instruments on the same platform, so that they have the same body temperature.
- 5) assuming that the electronics are independently calibrated, to analyse radiation values at normal incidence radiation (possibly tilting the radiometers to approximately normal incidence); if this is not possible to compare 1 hour totals around solar noon for horizontally mounted instruments.
- 6) for second class radiometers, to correct deviations of more than $\pm 10\%$. Lower deviations should be interpreted as acceptable and should not lead to a revised sensitivity (applicable to pyranometer type SR01 as used in the SRA01).
- 7) for first class pyranometers, to correct deviations of more than $\pm 5\%$. Lower deviations should be interpreted as acceptable and should not lead to a revised sensitivity (not applicable to SRA01).
- 8) for secondary standard instruments, to correct deviations of more than $\pm 3\%$. Lower deviations should be interpreted as acceptable and should not lead to a revised sensitivity (not applicable to SRA01).

6.4 Data quality assurance

Quality assurance of global solar irradiance can be done by:

- analysing trends in solar irradiance signal
- plotting the measured irradiance against mathematically generated expected values
- comparing irradiance measurements between sites
- analysis of night time signals

Quality assurance of reflected solar irradiance can be done by:

- analysing trends albedo over the day and from day to day
- comparing reflected irradiance and albedo measurements between sites
- analysis of night time signals

The main idea is that one should look out for any unrealistic values. There are programs on the market that can automatically perform data screening. See for more information on such a program <http://www.dqms.com>.

7 Appendices

7.1 Appendix on cable extension / replacement

The sensor cable can be removed and installed by the user provided that the cable is sealed at the sensor side against humidity ingress. Please consult Hukseflux for instructions on cable preparation or use Hukseflux-supplied parts.

SRA01 is equipped with one cable. Keep the distance between data logger or amplifier and sensor as short as possible. Cables act as a source of distortion by picking up capacitive noise. In an electrically “quiet” environment the SRA01 cable can however be extended without problem to 100 meters. If done properly, the sensor signal, although small, will not significantly degrade because the sensor resistance is very low (so good immunity to external sources) and because there is no current flowing (so no resistive losses).

Cable and connection specifications are summarised below.

NOTE: the body of SRA01 contains connector blocks that can be used for the internal connection of a new cable. See the chapter on electrical connections. Usually it is easier to connect a new extended cable inside the instrument body cable than to make a good (weatherproof) connection to an existing cable.

Table 7.1.1 Preferred specifications for cable extension of SRA01

General	please consult Hukseflux for instructions or use Hukseflux-supplied parts.
Cable	8-wire, shielded, with copper conductor (at Hukseflux 8-wire shielded cable is used, of which only 4 wires are used)
Sealing	sealed at the sensor side against humidity ingress
Core resistance	< 0.1 Ω /m
Cable outer diameter	5 to 6.5 x 10 ⁻³ m, to fit cable gland
Length	cables should be kept as short as possible, in any case the total cable length should be less than 100 m
Outer sheet	with specifications for outdoor use (for good stability in outdoor applications)
Connection	either solder the new cable core and shield to the original sensor cable, and make a waterproof connection using cable shrink, or use gold plated waterproof connectors. Always connect shield.

7.2 Appendix on tools for SRA01

Table 7.2.1 *Specifications of tools for SRA01*

tooling required for fixation to tube / rod / arm	hex key size 3 mm
tooling required for cable gland fixation and removal	spanner size 15 mm
Tooling required for fixation of the SR01 to SRA01 body	hex key size 2.5 mm
tooling required for wire fixation and removal (internal wiring inside SRA01 body)	screwdriver blade width 2 mm

7.3 Appendix on spare parts for SRA01

- SRA01 cable (specify length in multiples of 5 m), sealed at one end
- cable gland SRA01
- o-ring SRA01

7.4 Appendix on standards for classification and calibration

Both ISO and ASTM have standards on instrument classification and methods of calibration. The World Meteorological Organisation (WMO) has largely adopted the ISO classification system.

Table 7.4.1 *Pyranometer standardisation in ISO and ASTM*

STANDARDS ON INSTRUMENT CLASSIFICATION AND CALIBRATION	
ISO STANDARD	EQUIVALENT ASTM STANDARD
ISO 9060:1990 Solar energy -- Specification and classification of instruments for measuring hemispherical solar and direct solar radiation	not available Comment: work is in progress on a new ASTM equivalent standard
Comment: a standard "Solar energy --Methods for testing pyranometer and pyrhelimeter characteristics" has been announced in ISO 9060 but is not yet implemented.	not available
ISO 9846:1993 Solar energy -- Calibration of a pyranometer using a pyrhelimeter	ASTM G167 - 05 Standard Test Method for Calibration of a Pyranometer Using a Pyrhelimeter
ISO 9847:1992 Solar energy -- Calibration of field pyranometers by comparison to a reference pyranometer	ASTM E 824 -10 Standard Test Method for Transfer of Calibration from Reference to Field Radiometers ASTM G207 - 11 Standard Test Method for Indoor Transfer of Calibration from Reference to Field Pyranometers
ISO 9059:1990 Solar energy -- Calibration of field pyrhelimeters by comparison to a reference pyrhelimeter	ASTM E 816 Standard Test Method for Calibration of Pyrhelimeters by Comparison to Reference Pyrhelimeters

7.5 Appendix on calibration hierarchy

The World Radiometric Reference (WRR) is the measurement standard representing the SI unit of irradiance. It was introduced in order to ensure world-wide homogeneity of solar radiation measurements and is in use since 1980. The WRR was determined from the weighted mean of the measurements of a group of 15 absolute cavity radiometers which were fully characterised. It has an estimated accuracy of 0.3%. The WMO introduced its mandatory use in its status in 1979.

The world-wide homogeneity of the meteorological radiation measurements is guaranteed by the World Radiation Center in Davos Switzerland, by maintaining the World Standard Group (WSG) which materialises the World Radiometric Reference.

See <http://www.pmodwrc.ch>

The Hukseflux standard is traceable to an outdoor WRR calibration. Some small corrections are made to transfer this calibration to the Hukseflux standard conditions: sun at zenith and 1000 W/m² irradiance level. During the outdoor calibration the sun is typically at 20 to 40 ° zenith angle, and the total irradiance at a 700 W/m² level.

Table 7.5.1 Calibration hierarchy for pyranometers

WORKING STANDARD CALIBRATION AT PMOD / WRC DAVOS

Calibration of working standard pyranometers:

Method: ISO 9846, type 1 outdoor. This working standard has an uncertainty “uncertainty of standard”. The working standard has been calibrated under certain “test conditions of the standard”. The working standard has traceability to WRR world radiometric reference.

CORRECTION OF (WORKING) STANDARD CALIBRATION TO STANDARDISED REFERENCE CONDITIONS

Correction from “test conditions of the standard” to “reference conditions” i.e. to normal incidence and 20 °C:

Using known (working) standard pyranometer properties: directional, non linearity, offsets, temperature dependence). This correction has an uncertainty; “uncertainty of correction”.

At Hukseflux we also call the working standard pyranometer “standard”.

INDOOR PRODUCT CALIBRATION

Calibration of products, i.e. pyranometers:

Method: according to ISO 9847, Type IIc, which is an indoor calibration.

This calibration has an uncertainty associated with the method.

(In some cases like the BSRN network the product calibration is with a different method; for example again type 1 outdoor)

CALIBRATION UNCERTAINTY CALCULATION

ISO 98-3 Guide to the Expression of Uncertainty in Measurement, GUM Determination of combined expanded uncertainty of calibration of the product, including uncertainty of the working standard, uncertainty of correction, uncertainty of the method (transfer error). The coverage factor must be determined; at Hukseflux we work with a coverage factor $k = 2$.

7.6 Appendix on meteorological radiation quantities

A pyranometer measures irradiance. The time integrated total is called radiant exposure. In solar energy radiant exposure is often given in $W \cdot h/m^2$.

Table 7.6.1 Meteorological radiation quantities as recommended by WMO (additional symbols by Hukseflux Thermal Sensor). POA stands for Plane of Array irradiance. The term originates from ASTM and IEC standards.

SYMBOL	DESCRIPTION	CALCULATION	UNITS	ALTERNATIVE EXPRESSION	
$E \downarrow$	downward irradiance	$E \downarrow = E_g \downarrow + E_l \downarrow$	W/m^2		
$H \downarrow$	downward radiant exposure for a specified time interval	$H \downarrow = H_g \downarrow + H_l \downarrow$	J/m^2		
$E \uparrow$	upward irradiance	$E \uparrow = E_g \uparrow + E_l \uparrow$	W/m^2		
$H \uparrow$	upward radiant exposure for a specified time interval	$H \uparrow = H_g \uparrow + H_l \uparrow$	J/m^2	$W \cdot h/m^2$	Change of units
E	direct solar irradiance normal to the apparent solar zenith angle		W/m^2	DNI	Direct Normal Irradiance
E_0	solar constant		W/m^2		
$E_{g \downarrow h}$	global irradiance; hemispherical irradiance on a specified, in this case horizontal surface.*	$E_{g \downarrow} = E \cos \theta_h + E_d \downarrow$	W/m^2	GHI	Global Horizontal Irradiance
$E_{g \downarrow t}$	global irradiance; hemispherical irradiance on a specified, in this case tilted surface.*	$E_{g \downarrow} = E \cdot \cos \theta_t + E_d \downarrow_t + E_r \uparrow_t$ ***	W/m^2	POA	Plane of Array
$E_d \downarrow$	downward diffuse solar radiation		W/m^2	DHI	Diffuse Horizontal Irradiance
$E_l \uparrow, E_l \downarrow$	upward / downward long-wave irradiance		W/m^2		
$E_r \uparrow$	reflected solar irradiance		W/m^2		
E^*	net irradiance	$E^* = E \downarrow - E \uparrow$	W/m^2		
$T \downarrow$	apparent surface temperature**		$^{\circ}C$ or K		
$T \uparrow$	apparent sky temperature**		$^{\circ}C$ or K		
SD	sunshine duration		h		

θ is the apparent solar zenith angle θ_h relative to horizontal, θ_t relative to a tilted surface
 g = global, l = long wave, t = tilted *, h = horizontal*

* distinction horizontal and tilted by Hukseflux,

** T symbols introduced by Hukseflux,

*** contributions of $E_d \downarrow_t$ and $E_r \uparrow_t$ are $E_d \downarrow$ and $E_r \uparrow$ both corrected for the tilt angle of the surface

7.7 Appendix on ISO and WMO classification tables

Table 7.7.1 Classification table for pyranometers per ISO 9060 and WMO.

NOTE: WMO specification of spectral selectivity is different from that of ISO. Hukseflux conforms to the ISO limits. WMO also specifies achievable accuracies. ISO finds this not to be a part of the classification system because it also involves calibration. Please note that WMO achievable accuracies are for clear days at mid latitudes and that the uncertainty estimate does not include uncertainty due to calibration*.

ISO CLASSIFICATION** TABLE			
ISO CLASS	SECONDARY STANDARD	FIRST CLASS	SECOND CLASS
Specification limit			
Response time (95 %)	15 s	30 s	60 s
Zero offset a (response to 200 W/m ² net thermal radiation)	+ 7 W/m ²	+ 15 W/m ²	+ 30 W/m ²
Zero offset b (response to 5 K/h in ambient temperature)	± 2 W/m ²	± 4 W/m ²	± 8 W/m ²
Non-stability (change per year)	± 0.8 %	± 1.5 %	± 3 %
Non-linearity (100 to 1000 W/m ²)	± 0.5 %	± 1 %	± 3 %
Directional response	± 10 W/m ²	± 20 W/m ²	± 30 W/m ²
Spectral selectivity (350 to 1 500 x 10 ⁻⁹ m) (WMO 300 to 3 000 x 10 ⁻⁹ m)	± 3 %	± 5 %	± 10 %
Temperature response (interval of 50 K)**	2 %	4 %	8 %
Tilt response (0 to 90 ° at 1000 W/m ²)	± 0.5 %	± 2 %	± 5 %
ADDITIONAL WMO SPECIFICATIONS			
WMO CLASS	HIGH QUALITY	GOOD QUALITY	MODERATE QUALITY
WMO: achievable accuracy for daily sums*	2 %	5 %	10 %
WMO: achievable accuracy for hourly sums*	3 %	8 %	20 %
WMO: achievable accuracy for minute sums*	not specified	not specified	not specified
WMO: resolution (smallest detectable change)	1 W/m ²	5 W/m ²	10 W/m ²
CONFORMITY TESTING***			
ISO 9060	individual instrument only: all specs must comply	group compliance	group compliance

* WMO 7.2.1: The estimated uncertainties are based on the following assumptions: (a) instruments are well-maintained, correctly aligned and clean; (b) 1 min and 1 h figures are for clear-sky irradiances at solar noon; (c) daily exposure values are for clear days at mid-latitudes. WMO 7.3.2.5: Table 7.5 lists the expected maximum deviation from the true value, excluding calibration errors.

** At Hukseflux we use the expression ± 1 % instead of a range of 2 %.

*** an instrument is subject to conformity testing of its specifications. Depending on the classification, conformity compliance can be proven either by group- or individual compliance. A specification is fulfilled if the mean value of the respective test result does not exceed the corresponding limiting value of the specification for the specific category of instrument.

7.8 Appendix on definition of pyranometer specifications

Table 7.8.1 *Definition of pyranometer specifications*

SPECIFICATION	DEFINITION	SOURCE
Response time (95 %)	time for 95 % response. The time interval between the instant when a stimulus is subjected to a specified abrupt change and the instant when the response reaches and remains within specified limits around its final steady value. The response time is a measure of the thermal inertia inherent in the stabilization period for a final reading.	ISO 9060-1990 WMO 1.6.3
Zero offset a: (200 W/m ² net thermal radiation)	response to 200 W/m ² net thermal radiation (ventilated). Hukseflux assumes that unventilated instruments have to specify the zero-offset in unventilated – worst case – conditions. Zero offsets are a measure of the stability of the zero-point. Zero offset a is visible at night as a negative offset, the instrument dome irradiates in the far infra red to the relatively cold sky. This causes the dome to cool down. The pyranometer sensor irradiates to the relatively cool dome, causing a negative offset. Zero offset a is also assumed to be present during daytime.	ISO 9060-1990
Zero offset b: (5 K/h in ambient temperature)	response to 5 K/h change in ambient temperature. Zero offsets are a measure of the stability of the zero-point.	ISO 9060-1990
Non-stability (change per year)	percentage change in sensitivity per year. The dependence of sensitivity resulting from ageing effects which is a measure of the long-term stability.	ISO 9060-1990
Non-linearity (100 to 1000 W/m ²)	percentage deviation from the sensitivity at 500 W/m ² due to the change in irradiance within the range of 100 W/m ² to 1000 W/m ² . Non-linearity has an overlap with directional response, and therefore should be handled with care in uncertainty evaluation.	ISO 9060-1990
Directional response	the range of errors caused by assuming that the normal incidence sensitivity is valid for all directions when measuring from any direction a beam radiation whose normal incidence irradiance is 1000 W/m ² . Directional response is a measure of the deviations from the ideal “cosine behaviour” and its azimuthal variation.	ISO 9060-1990
Spectral selectivity (350 to 1500 x 10 ⁻⁹ m) (WMO 300 to 3000 x 10 ⁻⁹ m)	percentage deviation of the product of spectral absorptance and spectral transmittance from the corresponding mean within mean within the specified spectral range. Spectral selectivity is a measure of the spectral selectivity of the sensitivity.	ISO 9060-1990
Temperature response (interval of 50 K)	percentage deviation of the sensitivity due to change in ambient temperature within an interval of 50 K the temperature of the pyranometer body.	ISO 9060-1990
Tilt response (0 ° to 90 ° at 1000 W/m ²)	percentage deviation from the sensitivity at 0 ° tilt (horizontal) due to change in tilt from 0 ° to 90 ° at 1000 W/m ² irradiance. Tilt response describes changes of the sensitivity due to changes of the tilt angle of the receiving surface.	ISO 9060-1990
Sensitivity	the change in the response of a measuring instrument divided by the corresponding change in the stimulus.	WMO 1.6.3
Spectral range	the spectral range of radiation to which the instrument is sensitive. For a normal pyranometer this should be in the 0.3 to 3 x 10 ⁻⁶ m range. Some pyranometers with coloured glass domes have a limited spectral range.	Hukseflux

7.9 Appendix on terminology / glossary

Table 7.9.1 Definitions and references of used terms

TERM	DEFINITION (REFERENCE)
Solar energy or solar radiation	solar energy is the electromagnetic energy emitted by the sun. Solar energy is also called solar radiation and shortwave radiation. The solar radiation incident on the top of the terrestrial atmosphere is called extra-terrestrial solar radiation; 97 % of which is confined to the spectral range of 290 to $3\,000 \times 10^{-9}$ m. Part of the extra-terrestrial solar radiation penetrates the atmosphere and directly reaches the earth's surface, while part of it is scattered and / or absorbed by the gas molecules, aerosol particles, cloud droplets and cloud crystals in the atmosphere. The former is the direct component, the latter is the diffuse component of the solar radiation. (ref: WMO, Hukseflux)
Hemispherical solar radiation	solar radiation received by a plane surface from a 180° field of view angle (solid angle of 2π sr).(ref: ISO 9060)
Global solar radiation	the solar radiation received from a 180° field of view angle on a horizontal surface is referred to as global radiation. Also called GHI. This includes radiation received directly from the solid angle of the sun's disc, as well as diffuse sky radiation that has been scattered in traversing the atmosphere. (ref: WMO) Hemispherical solar radiation received by a horizontal plane surface. (ref: ISO 9060)
Plane-of-array irradiance	also POA: hemispherical solar irradiance in the plane of a PV array. (ref: ASTM E2848-11 / IEC 61724)
Direct solar radiation	radiation received from a small solid angle centred on the sun's disc, on a given plane. (ref: ISO 9060)
Terrestrial or Longwave radiation	radiation not of solar origin but of terrestrial and atmospheric origin and having longer wavelengths ($3\,000$ to $100\,000 \times 10^{-9}$ m). In case of downwelling $E_i \downarrow$ also the background radiation from the universe is involved, passing through the "atmospheric window". In case of upwelling $E_i \uparrow$, composed of long-wave electromagnetic energy emitted by the earth's surface and by the gases, aerosols and clouds of the atmosphere; it is also partly absorbed within the atmosphere. For a temperature of 300 K, 99.99 % of the power of the terrestrial radiation has a wavelength longer than $3\,000 \times 10^{-9}$ m and about 99 per cent longer than $5\,000 \times 10^{-9}$ m. For lower temperatures, the spectrum shifts to longer wavelengths. (ref: WMO)
World Radiometric Reference (WRR)	measurement standard representing the SI unit of irradiance with an uncertainty of less than $\pm 0.3\%$ (see the WMO Guide to Meteorological Instruments and Methods of Observation, 1983, subclause 9.1.3). The reference was adopted by the World Meteorological Organization (WMO) and has been in effect since 1 July 1980. (ref: ISO 9060)
Albedo	ratio of reflected and incoming solar radiation. Dimensionless number that varies between 0 and 1. Typical albedo values are: < 0.1 for water, from 0.1 for wet soils to 0.5 for dry sand, from 0.1 to 0.4 for vegetation, up to 0.9 for fresh snow.
Angle of incidence	angle of radiation relative to the sensor measured from normal incidence (varies from 0° to 90°).
Zenith angle	angle of incidence of radiation, relative to zenith. Equals angle of incidence for horizontally mounted instruments
Azimuth angle	angle of incidence of radiation, projected in the plane of the sensor surface. Varies from 0° to 360° . 0 is by definition the cable exit direction, also called north, east is $+90^\circ$. (ASTM G13-09)
Sunshine duration	sunshine duration during a given period is defined as the sum of that sub-period for which the direct solar irradiance exceeds 120 W/m^2 . (ref: WMO)

7.10 EC declaration of conformity



We, Hukseflux Thermal Sensors B.V.
Delftechpark 31
2628 XJ Delft
The Netherlands

in accordance with the requirements of the following directive:

2004/108/EC The Electromagnetic Compatibility Directive

hereby declare under our sole responsibility that:

Product model: SRA01
Product type: Albedometer

has been designed to comply and is in conformity with the relevant sections and applicable requirements of the following standards:

Emission: EN 61326-1 (2006)
Immunity: EN 61326-1 (2006)
Emission: EN 61000-3-2 (2006)
Emission: EN 61000-3-3 (1995) + A1 (2001) + A2 (2005).
Report: 08C01340RPT01, 06 January 2009

A handwritten signature in blue ink, appearing to be 'E. Hoeksema'.

Eric HOEKSEMA
Director
Delft
03 July, 2012

