

USER MANUAL **HF05**

Industrial heat flux sensor



Warning statements



Follow the installation instructions of this user manual.



The sensor and sensor-to-cable transition should not be exposed to significant force.



Putting more than 12 Volt across the sensor wiring can lead to permanent damage to the sensor.



Do not use “open circuit detection” when measuring the sensor output.



Only for supply with the optional CE type examination (ATEX) certificate: ask the supplier for ATEX rated operating conditions.

Contents

Warning statements	2
Contents	3
List of symbols	4
Introduction	5
1 Ordering and checking at delivery	7
1.1 Ordering HF05	7
1.2 Included items	7
1.3 Quick instrument check	7
2 Instrument principle and theory	8
3 Specifications of HF05	10
3.2 Dimensions of HF05	13
4 Standards and recommended practices for use	14
4.1 Heat flux measurement in industry	14
5 Installation of HF05	16
5.1 Site selection and installation in industry	16
5.2 Electrical connection	18
5.3 Requirements for data acquisition / amplification	19
6 Maintenance and trouble shooting	20
6.1 Recommended maintenance and quality assurance	20
6.2 Trouble shooting	21
6.3 Calibration and checks in the field	22
7 Appendices	24
7.1 Appendix on uncertainty evaluation	24
7.2 Appendix on cable extension / replacement	24
7.3 Appendix on calibration hierarchy	25
7.4 EU declaration of conformity	26

List of symbols

Quantities

Heat flux
Voltage output
Sensitivity
Temperature
Temperature difference
Resistance

Symbol

Φ
U
S
T
 ΔT
R

Unit

W/m²
V
V/(W/m²)
°C
°C, K
 Ω

Subscripts

property of thermopile sensor
calibration reference condition
property of the object on which HF05 is mounted
property at the (object) surface
property of the surrounding environment

sensor
reference
object
surface
environment

Introduction

HF05 measures heat flux and surface temperature in industrial environments. The sensor has a fully sealed stainless steel body and a PTFE cable. It is robust, stable and can withstand relatively extreme environmental conditions. It is suitable for long term use at one location as well as repeated installation when a measuring system is used at multiple locations.

HF05 measures heat flux through the object on which it is mounted, in W/m^2 , as well as its surface temperature in $^{\circ}C$. The sensors in HF05 are a thermopile and a type K thermocouple. The thermopile measures the temperature difference across the body of HF05, creating an output that is representative of the local heat flux. The thermocouple measures the absolute temperature of the surface on which HF05 is mounted. A thermopile and a thermocouple are passive sensors; they do not require power.

Using HF05 is easy. It can be connected directly to commonly used data logging systems. The heat flux, Φ , in W/m^2 , is calculated by dividing the HF05 output, a small voltage U , by the sensitivity S .

The measurement function of HF05 is:

$$\Phi = U/S \quad \text{(Formula 0.1)}$$

The sensitivity is provided with HF05 on its product certificate.

HF05 complies with the requirements of ASTM C1041-85 (2007) Standard Practice for In-Situ Measurements of Heat Flux in Industrial Thermal Insulation Using Heat Flux Transducers.

Equipped with heavy duty cabling, and having a fully stainless steel casing so that moisture does not penetrate the sensor, HF05 has proven to be very reliable. It survives long-term outdoor installation.

HF05 is most suitable for relative measurements, i.e. monitoring of trends relative to a certain reference point in time or comparing heat flux at one location to the heat flux at another location. Typical applications of HF05 are studies of fouling in industrial environments mounted on tubing or on the jacket of reactors. HF05 is also used for performance evaluation of industrial insulation.

If the user wants to perform accurate absolute measurements with HF05, as opposed to relative measurements, the user must make his own uncertainty evaluation and correction for systematic errors. See the appendix on uncertainty evaluation. However, in many situations the analysis of trends is sufficient. In that case a high absolute measurement accuracy is not needed, and a formal uncertainty evaluation is not necessary.

HF05 calibration is traceable to international standards. The factory calibration method follows the recommended practice of ASTM C1130. The recommended calibration interval of heat flux sensors is 2 years.

Suggested use of HF05:

- industrial heat flux measurements
- performance evaluation of industrial insulation

See also:

- model [HF01](#) for higher temperatures up to 800 °C
- model [HF01](#) for lower temperatures up to 70 °C
- our complete [product range of heat flux sensors](#)
- our range of [industrial heat flux sensors](#) (PDF)



Figure 0.1 *HF05 industrial heat flux sensor*

1 Ordering and checking at delivery

1.1 Ordering HF05

The standard configuration of HF05 is with 3 metres cable.

Common options are:

- longer cable (specify total cable length in m)
- connector at HF05 cable end
- EC type examination certificate (ATEX) II 2 G EEx d IIC T6
- extension cable with 2 connectors matching cable connector and chassis connector (specify cable length in m)
- chassis connector with internal wiring (colour code of wiring identical to cable colour code)

1.2 Included items

Arriving at the customer, the delivery should include:

- heat flux sensor HF05
- cable of the length as ordered
- product certificate matching the instrument serial number

1.3 Quick instrument check

A quick test of the instrument can be done by connecting it to a multimeter.

1 Check the electrical resistance of the heat flux sensor between the black [-] and red [+] wires and the thermocouple between the green [+] and white [-] wires. Use a multimeter at the 100 Ω range. Measure the sensor resistance first with one polarity, then reverse the polarity. Take the average value. Typical resistance should be the nominal sensor resistance of 3 Ω for the thermopile sensor plus 0.2 Ω /m (resistance per meter cable) for the total resistance of two wires (back and forth added). For the thermocouple work with 3 Ω /m resistance per meter cable. Infinite resistance indicates a broken circuit; zero or a lower than 1 Ω resistance indicates a short circuit.

2. Check if the heat flux sensor reacts to heat: put the multimeter at its most sensitive range of DC voltage measurement, typically the 100 x 10⁻³ VDC range or lower. Expose the sensor heat, for instance touching it with your hand. The signal should read > 2 x 10⁻³ V now. Touching or exposing the red side should generate a positive signal, doing the same at the opposite side, the sign of the output voltage reverses. Also look at the reaction of the thermocouple to heat. The thermocouple is located at the side flush with the flanges.

3. Inspect the instrument for any damage.

4. Check the sensor serial number engraved on the sensor side against the certificate provided with the sensor.

2 Instrument principle and theory

HF05's scientific name is heat flux sensor. A heat flux sensor measures the heat flux density through the sensor itself. This quantity, expressed in W/m^2 , is usually called "heat flux". HF05 users typically assume that the measured heat flux is representative of the undisturbed heat flux at the location of the sensor. Users may also apply corrections based on scientific judgement.

The heat flux sensor in HF05 is a thermopile. This thermopile measures the temperature difference across the body of HF05. Working completely passive, the thermopile generates a small voltage that is a linear function of this temperature difference. The heat flux is proportional to the same temperature difference divided by the effective thermal conductivity of the heat flux sensor body. Using HF05 is easy. For readout the user only needs an accurate voltmeter that works in the millivolt range. To convert the measured voltage, U , to a heat flux Φ , the voltage must be divided by the sensitivity S , a constant that is supplied with each individual sensor.

The temperature sensor inside HF05 is a type K thermocouple located at the side of the sensor flush with the flanges.

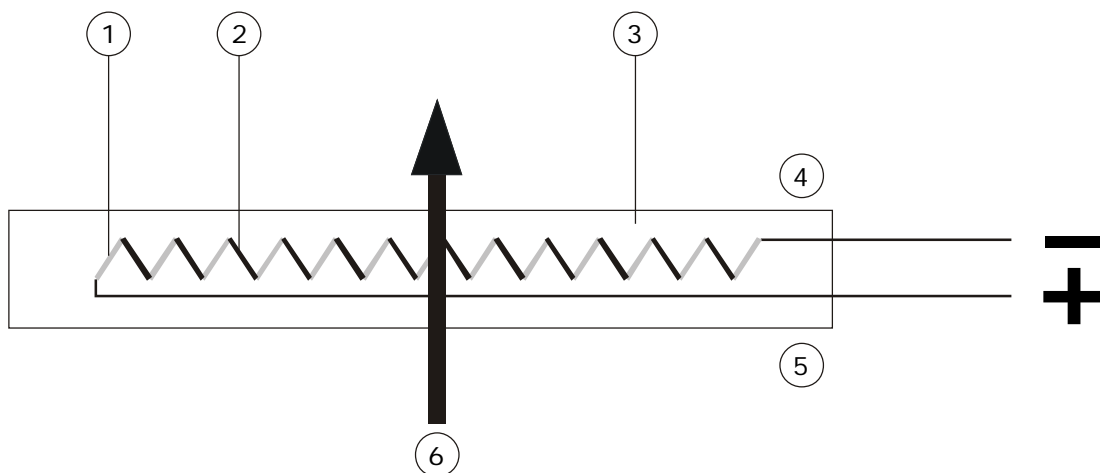

Figure 2.1 The general working principle of a heat flux sensor. The sensor inside HF05 is a thermopile. A thermopile consists of a number of thermocouples, each consisting of two metal alloys marked 1 and 2, electrically connected in series. A single thermocouple will generate an output voltage that is proportional to the temperature difference between its hot- and cold joints. Putting thermocouples in series amplifies the signal. In a heat flux sensor, the hot- and cold joints are located at the opposite sensor surfaces 4 and 5. In steady state, the heat flux 6 is a linear function of the temperature difference across the sensor and the average thermal conductivity of the sensor body, 3. The thermopile generates a voltage output proportional to the heat flux through the sensor. The exact sensitivity of the sensor is determined at the manufacturer by calibration, and is found on the calibration certificate that is supplied with each sensor.

Heat flux sensors such as HF05, for use in industry, are typically calibrated under the following reference conditions:

- conductive heat flux (as opposed to radiative or convective heat flux)
- homogeneous heat flux across the sensor and guard surface
- room temperature
- heat flux in the order of 350 W/m^2

Unique features of HF05 are:

- low electrical resistance (low pickup of electrical noise)
- high sensitivity (good signal to noise ratio in low-flux environments such as buildings)
- robustness, including a strong cable
- built-in temperature sensor; type K thermocouple
- IP protection class: IP67 (essential for outdoor application)

Measuring with heat flux sensors, errors may be caused by differences between calibration reference conditions and the conditions during use. The user should analyse his own experiment and make his own uncertainty evaluation.

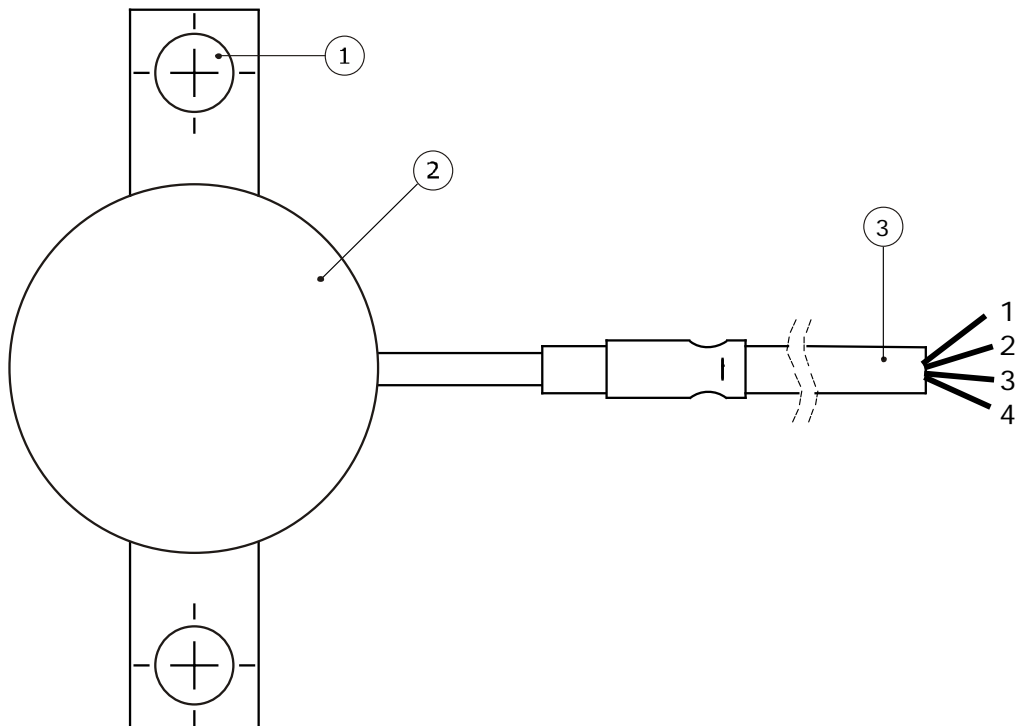

Figure 2.2 HF05: the heat flux sensor (2) is connected to a short rigid stainless steel tube. This sensor-to-cable transition is connected to a PTFE cable (3). Two mounting flanges (1) are attached to the sensor body.

3 Specifications of HF05

3.1 Specifications of HF05

HF05 measures the heat flux density through the surface of the sensor. This quantity, expressed in W/m^2 , is called heat flux. It also measures the absolute temperature of the surface on which it is mounted. HF05 is passive, using thermopile and thermocouple sensors. The thermopile generates a small output voltage proportional to the heat flux. HF05 can only be used in combination with a suitable measurement system. The sensor should be used in accordance with the recommended practices of ASTM.

Table 3.1 *Specifications of HF05 (continued on next page)*

HF05 SPECIFICATIONS	
Sensor type	industrial heat flux sensor
Sensor type according to ASTM	heat flow sensor or heat flux transducer
Heat flux sensor	thermopile
Measurand	heat flux
Measurand in SI units	heat flux density in W/m^2
Measurement range	-6000 to 6000 W/m^2
Temperature sensor	thermocouple type K
Temperature sensor specification	ANSI MC96.1-1982 / EN 60584
Measurand	temperature
Measurand in SI units	temperature in $^{\circ}C$
Measurement function / required programming	$\Phi = U/S$
Sensitivity range	10 to 25 x 10^{-6} V/(W/m^2)
Recommended number of sensors	2 per measurement location
Sensitivity (nominal)	15 x 10^{-6} V/(W/m^2)
Response time (95 %)	300 s (nominal)
Directional sensitivity	heat flux from the side flush with the flanges (marked X) to the opposite side generates a positive voltage output signal
Expected voltage output	multiply the sensitivity by the maximum expected heat flux
Required readout	heat flux sensor: 1 x differential voltage channel or 1 x single ended voltage channel temperature sensor: 1 x Type K differential thermocouple channel or 1 x Type K single ended thermocouple channel both with input resistance > $10^6 \Omega$
Rated operating temperature range	-30 to +170 $^{\circ}C$
IP protection class	IP67
Rated operating relative humidity range	0 to 100 %
Required sensor power	zero (passive sensors)
Temperature dependence	< 0.1 %/ $^{\circ}C$
Non-stability	< 1 %/yr (for typical use)
Sensor diameter	40 x 10^{-3} m
Sensor thickness	5.0 x 10^{-3} m
Heat flux sensor resistance (nominal)	3 Ω
Heat flux sensor cable resistance	0.2 Ω/m
Temperature sensor resistance	3 Ω/m

Table 3.1 Specifications of HF05 (started on previous page, continued on the next page)

Standard cable length (see options)	3 m
Cable diameter	4×10^{-3} m
Marking	1 x engraving on the sensor side, showing serial number 1 x sticker at cable end, wrapped around the sensor cable, showing serial number.
Gross weight including 3 m cable	0.25 kg
Net weight including 3 m cable	0.20 kg
Packaging	box of 220 x 155 x 30 mm
INSTALLATION AND USE	
Standards governing use of the instrument	ASTM C1041-85 (2007) Standard Practice for In-Situ Measurements of Heat Flux in Industrial Thermal Insulation Using Heat Flux Transducers
Orientation	the side flush with the flanges (marked X) must be in contact with the object on which the sensor is mounted
Installation	see recommendations in this user manual. Avoid mechanical force on the flanges, sensor body and sensor-to-cable transition.
Cable extension	see options: longer cable, extension cable and connectors
Optional connectors on HF05 cable and extension cable	LEMO brand, 12×10^{-3} m outer diameter
CALIBRATION	
Calibration traceability	to SI units
Product certificate	included (showing calibration result and traceability)
Calibration method	method HFC, using a dedicated HF05 adapter, according to ASTM C1130
Calibration hierarchy	From SI through international standards and through an internal mathematical procedure
Calibration uncertainty	$\pm 10\%$ ($k = 2$)
Recommended recalibration interval	2 years
Calibration reference conditions	20 °C, heat flux of 350 W/m ² , thermal conductivity of the surrounding environment 0.0 W/(m·K)
Validity of calibration	based on experience the instrument sensitivity will not change during storage. During use the instrument "non-stability" specification is applicable.
Field calibration	is possible by comparison to a calibration reference sensor. Usually mounted side by side. Preferably reference and field sensor of the same model and brand. Typical duration of test > 24 h.
Temperature sensor tolerance class	IEC Tolerance class EN60584-2: Type K, class 2
Temperature sensor error limits	ASTM E230-ANSI MC96.1: Type K, standard limits

Table 3.1 *Specifications of HF05 (started on previous 2 pages)*

MEASUREMENT ACCURACY	
Uncertainty of the measurement	statements about the overall measurement uncertainty can only be made on an individual basis. see the chapter on uncertainty evaluation.
VERSIONS / OPTIONS	
Order code	HF05 / cable length in m
Longer cable	longer cable (specify total cable length in m)
EC type examination certificate (ATEX)	II 2 G EEx d IIC T6
Extension cable	extension cable with 2 connectors matching cable connector and chassis connector (specify cable length in m)
Connector	connector at HF05 cable end
Chassis connector	chassis connector with internal wiring (colour code of wiring identical to cable colour code)

3.2 Dimensions of HF05

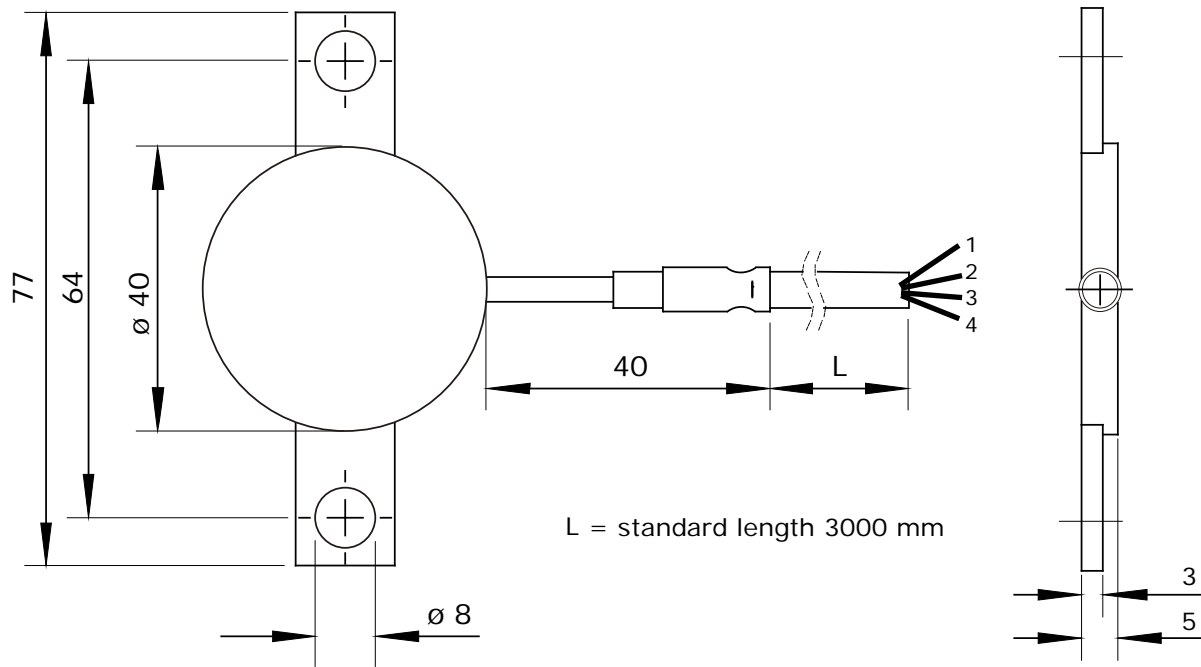

Figure 3.2.1 HF05 heat flux sensor dimensions in $\times 10^{-3} \text{ m}$.

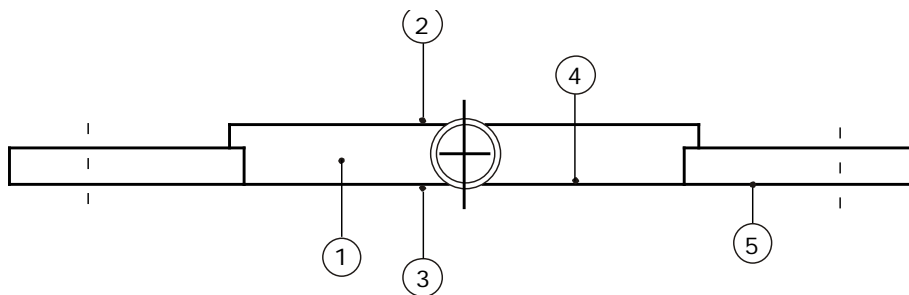

Figure 3.2.2 Features of HF05

- (1) engraved serial number
- (2) non-object side
- (3) object side (flush with mounting flanges)
- (4) location temperature sensor (in body)
- (5) side flush with mounting flanges is engraved with marker 'X'

4 Standards and recommended practices for use

HF05 should be used in accordance with the recommended practices of ASTM.

4.1 Heat flux measurement in industry

Many HF05 sensors measure on industrial walls and metal surfaces, estimating the installation's energy balance and the thermal transmission of walls. Typically the total measuring system consists of multiple heat flux- and temperature sensors. In many cases heat flux sensors are used for trend-monitoring. In such cases reproducibility is more important than absolute measurement accuracy.



Figure 4.1.1 Example of an industrial heat flux sensor mounted on a boiler wall using tack-welded threads and spring-loaded bolts. The sensor is mounted on a well prepared flat surface. Cabling must be provided with strain relief.

Table 4.1.1 contains a listing of applicable standards. We recommend users to purchase the latest version of the standard.

4.1.1 Applicable standards

Table 4.1.1 *Standards with recommendations for instrument use in industry*

STANDARDS FOR INSTRUMENT USE FOR BUILDING ENVELOPE THERMAL RESISTANCE MEASUREMENT	
ASTM STANDARD	EQUIVALENT ISO STANDARD
ASTM C1041-85 (2007) Standard Practice for In-Situ Measurements of Heat Flux in Industrial Thermal Insulation Using Heat Flux Transducers.	Not available

5 Installation of HF05

5.1 Site selection and installation in industry

Table 5.1.1 *Recommendations for installation of HF05 heat flux sensors*

Location	<p>choose a location that is representative of the process that is analysed if possible, avoid exposure to sun, rain, etc.</p> <p>do not expose to drafts and lateral heat fluxes</p> <p>do not mount in the vicinity of thermal bridges, cracks, heating or cooling devices and fans</p>
Performing a representative measurement / recommended number of sensors	<p>we recommend using > 2 sensors per measurement location. This redundancy also improves the assessment of the measurement accuracy</p>
Orientation	<p>mount with the flanges flush with the object, see figure 5.1.1. Mounted on vertical surfaces, the cable exit from the sensor should point down.</p>
Surface cleaning and levelling	<p>create a clean and smooth surface with a diameter of 80×10^{-3} m, so that the air gap between sensor and object surface is less than 0.2×10^{-3} m</p>
Mechanical mounting: avoiding strain on the sensor to cable transition	<p>the sensor-to-cable transition is vulnerable.</p> <p>during installation as well as operation, the user should provide proper strain relief of the cable so that transition is not exposed to significant force.</p> <p>first install the cable including strain relief and after that install the sensor.</p>
Mechanical mounting: using the mounting flanges	<p>the sensor body withstands only limited pressure and strain. users should not exert significant mechanical force on the flanges.</p> <p>tack-weld or screw M6 thread to the surface on which HF05 is mounted at a hart-to-hart distance of 64×10^{-3} m. Bolts holding the sensor should be used for positioning and for loose fixation only, and should be spring-loaded to guarantee good sensor to surface contact without exerting too much force.</p>
Permanent installation	<p>for long-term installation fill up the space between sensor and object with silicone construction sealant, silicone glue or silicone adhesive, that can be bought in construction depots. Use this in combination with the spring-loaded threads.</p> <p>we discourage the use of thermal paste because it tends to dry out. silicone glue is more stable and reliable.</p>
Signal amplification	<p>see the paragraph on electrical connection</p>

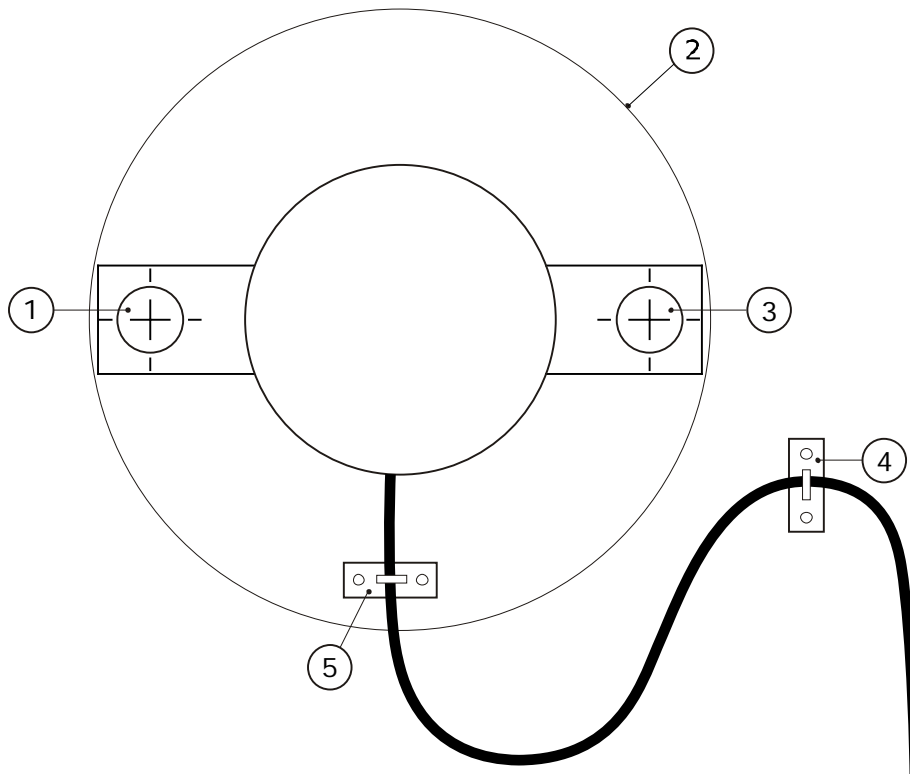

Figure 5.1.1 *Installation of HF05*

- (1+3) *spring loaded bolts*
- (2) *smooth 80×10^{-3} m diameter area for mounting HF05*
- (4+5) *cable strain relief*

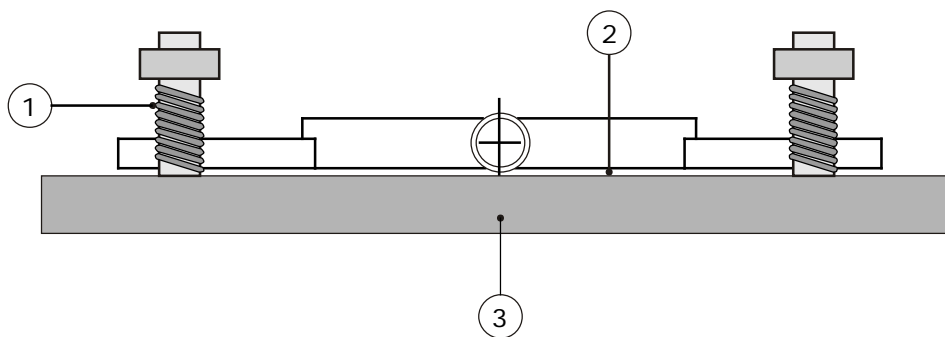

Figure 5.1.2 *Installation of HF05*

- (1) *spring loaded M6 thread*
- (2) *optional silicone glue between sensor body and object*
- (3) *object to be measured*

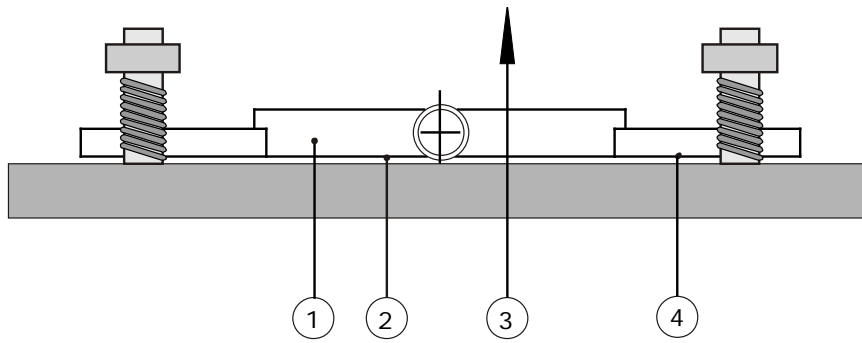

Figure 5.1.3 *Installation of HF05*

- (1) *engraved serial number*
- (2) *HF05 side of object to be measured, flush with flanges*
- (3) *heat flux generating positive signal*
- (4) *engraved with marker 'X'*

5.2 Electrical connection

A heat flux sensor should be connected to a measurement system, typically a so-called datalogger. HF05 is a passive sensor that does not need any power, neither for the heat flux sensor, nor for the temperature sensor. Cables may act as a source of distortion, by picking up capacitive noise. We recommend keeping the distance between a datalogger or amplifier and the sensor as short as possible. For cable extension, see the appendix on this subject.

Table 5.2.1 *The electrical connection of HF05. The shield is not connected to the stainless steel sensor body*

WIRE	
Red	heat flux signal [+]
Black	heat flux signal [-]
Green	thermocouple type K [+]
White	thermocouple type K [-]
Blank	shield

5.3 Requirements for data acquisition / amplification

The selection and programming of dataloggers is the responsibility of the user. Please contact the supplier of the data acquisition and amplification equipment to see if directions for use with the HF05 are available.

Table 5.3.1 *Requirements for data acquisition and amplification equipment for HF05 in the standard configuration*

Capability to measure small voltage signals	preferably: $< 5 \times 10^{-6}$ V uncertainty Minimum requirement: 20×10^{-6} V uncertainty (valid for the entire expected temperature range of the acquisition / amplification equipment)
Capability for the data logger or the software	to store data, and to perform division by the sensitivity to calculate the heat flux. $\Phi = U/S$ (Equation 0.1)
Capability to measure thermocouple type K	preferably: measurement uncertainty within ± 3 °C
Data acquisition input resistance	$> 1 \times 10^6 \Omega$
Open circuit detection (WARNING)	open-circuit detection should not be used, unless this is done separately from the normal measurement by more than 5 times the sensor response time and with a small current only. Thermopile and thermocouple sensors are sensitive to the current that is used during open circuit detection. The current will generate heat, which is measured and will appear as a temporary offset.

6 Maintenance and trouble shooting

6.1 Recommended maintenance and quality assurance

HF05 measures reliably at a low level of maintenance. Unreliable measurement results are detected by scientific judgement, for example by looking for unreasonably large or small measured values. The preferred way to obtain a reliable measurement is a regular critical review of the measured data, preferably checking against other measurements.

Table 6.1.1 *Recommended maintenance of HF05. If possible the data analysis is done on a daily basis.*

MINIMUM RECOMMENDED HEAT FLUX SENSOR MAINTENANCE			
	INTERVAL	SUBJECT	ACTION
1	1 week	data analysis	compare measured data to the maximum possible or maximum expected heat flux and to other measurements for example from nearby or redundant instruments. Historical seasonal records can be used as a source for expected values. Look for any patterns and events that deviate from what is normal or expected. Compare to acceptance intervals.
2	6 months	inspection	inspect cable quality, inspect mounting, inspect location of installation look for seasonal patterns in measurement data
3	2 years	recalibration	recalibration by comparison to a calibration standard instrument in the field, see following paragraphs. recalibration by the sensor manufacturer
4		lifetime assessment	judge if the instrument will be reliable for another 2 years, or if it should be replaced

6.2 Trouble shooting

Table 6.2.1 *Trouble shooting for HF05*

General	<p>Inspect the sensor for any damage. Inspect the quality of mounting / installation. Inspect if the wires are properly attached to the data logger. Check the condition of the cable. Inspect the connection of the shield (typically connected at the datalogger side). Check the datalogger program in particular if the right sensitivity is entered. HF05 serial number is engraved on the side of the sensor body. The sensitivity can be found on the calibration certificate.</p> <p>Check the electrical resistance of the heat flux sensor between the black [-] and red [+] wires and the thermocouple between the green [+] and white [-] wires. Use a multimeter at the 100 Ω range. Measure the sensor resistance first with one polarity, then reverse the polarity. Take the average value. Typical resistance should be the nominal sensor resistance of 3 Ω for the thermopile sensor plus 0.2 Ω/m (resistance per meter cable) for the total resistance of two wires (back and forth added). For the thermocouple work with 3 Ω/m resistance per meter cable. Infinite resistance indicates a broken circuit; zero or a lower than 1 Ω resistance indicates a short circuit.</p>
The sensor does not give any signal	<p>Check if the heat flux sensor reacts to heat: put the multimeter at its most sensitive range of DC voltage measurement, typically the 100 x 10⁻³ VDC range or lower. Expose the sensor heat, for instance touching it with your hand. The signal should read > 2 x 10⁻³ V now. Touching or exposing the red side should generate a positive signal, doing the same at the opposite side, the sign of the output voltage reverses.</p> <p>Also look at the reaction of the thermocouple to heat. Check the reaction of the thermocouple sensor to heat. Check the data acquisition by replacing the sensor with a spare unit.</p>
The sensor signal is unrealistically high or low	<p>Check the cable condition looking for cable breaks. Check the data acquisition by applying a 1 x 10⁻⁶ V source to it in the 1 x 10⁻⁶ V range. Look at the measurement result. Check if it is as expected. Check the data acquisition by short circuiting the data acquisition input with a 10 Ω resistor. Look at the output. Check if the output is close to 0 W/m².</p>
The sensor signal shows unexpected variations	<p>Check the presence of strong sources of electromagnetic radiation (radar, radio). Check the condition and connection of the shield. Check the condition of the sensor cable. Check if the cable is not moving during the measurement.</p>

6.3 Calibration and checks in the field

The recommended calibration interval of heat flux sensors is 2 years.
Recalibration of field heat flux sensors is ideally done by the sensor manufacturer.

On-site field calibration is possible by comparison to a calibration reference sensor, usually mounted side by side, alternatively mounted on top of the field sensor.

Hukseflux main recommendations for field calibrations are:

- 1) to compare to a calibration reference of the same brand and type as the field sensor
- 2) to connect both to the same electronics, so that electronics errors (also offsets) are eliminated.
- 3) to mount all sensors on the same platform, so that they have the same body temperature.
- 4) typical duration of test: > 24 h
- 5) typical heat fluxes used for comparison: > 20 W/m², preferably > 200 W/m²
- 6) to correct deviations of more than $\pm 10\%$. Lower deviations should be interpreted as acceptable and should not lead to a revised sensitivity.

7 Appendices

7.1 Appendix on uncertainty evaluation

If the user wants to perform accurate absolute measurements, as opposed to relative measurements, we recommend that the user calibrates sensors under his own responsibility under "simulated service conditions", and make his own correction for systematic errors and uncertainty evaluation.

The uncertainty of a measurement with HF05 is a function of:

- calibration uncertainty
- differences between reference conditions during calibration and measurement conditions, for example uncertainty caused by temperature dependence of the sensitivity
- the duration of sensor employment (involving the non-stability)
- application errors: the measurement conditions and environment in relation to the sensor properties, the influence of the sensor on the measurand, the representativeness of the measurement location

If the user knows the total power generated by a process the user may calibrate the heat flux measurement by comparison of heat fluxes multiplied by surface areas to the total generated power. Some users apply (temporary) electrical heaters to calibrate the sensors.

7.2 Appendix on cable extension / replacement

HF05 is equipped with one cable. Keep the distance between data logger or amplifier and sensor as short as possible. Cables may act as a source of distortion by picking up capacitive noise. In an electrically "quiet" environment the HF05 cable may be extended without problem to 50 metres. If done properly, the sensor signal, although small, will not significantly degrade because the sensor resistance is very low (which results in good immunity to external sources) and because there is no current flowing (so no resistive losses). Cable and connection specifications are summarised in table 7.2.1.

Table 7.2.1 Preferred specifications for cable extension of HF05

Cable	Hukseflux HF05 cable
Extension	<p>Use Hukseflux extension cable with 2 connectors matching cable connector and chassis connector (specify cable length in m)</p> <p>Use Hukseflux HF05 cable connector on the HF05 cable to a connector of the extension cable with 2 connectors</p> <p>Use Hukseflux chassis connector</p>
Outer diameter	4×10^{-3} m
Length	cables should be kept as short as possible, in any case the total cable length should be less than 50 m

7.3 Appendix on calibration hierarchy

HF05 factory calibration is traceable from SI through international standards and through an internal mathematical procedure which corrects for known errors. The formal traceability of the generated heat flux is through voltage and current to electrical power and electric power and through length to surface area.

The Hukseflux HFC method follows the recommended practice of ASTM C1130. It relies on a thin heater apparatus according to principles as described in paragraph 4 of ASTM C1114-06, in the single sided mode of operation described in paragraph 8.2 and in ASTM C1044.

7.4 EU declaration of conformity



We, Hukseflux Thermal Sensors B.V.
Delftechpark 31
2628 XJ Delft
The Netherlands

in accordance with the requirements of the following directive:

2014/30/EU The Electromagnetic Compatibility Directive

hereby declare under our sole responsibility that:

Product model: HF05
Product type: Industrial heat flux sensor

has been designed to comply and is in conformity with the relevant sections and applicable requirements of the following standards:

Emission: EN 61326-1 (2006)
Immunity: EN 61326-1 (2006)
Emission: EN 61000-3-2 (2006)
Emission: EN 61000-3-3 (1995) + A1 (2001) + A2 (2005)
Report: 08C01340RPT01, 06 January 2009



Eric HOEKSEMA
Director
Delft
September 08, 2015

