

USER MANUAL FHF02SC

Self-calibrating foil heat flux sensor
with thermal spreaders and heater



Warning statements



Putting more than 24 Volt across the heater wiring can lead to permanent damage to the sensor.



Do not use "open circuit detection" when measuring the sensor output.

Contents

Warning statements	2
Contents	3
List of symbols	4
Introduction	5
1 Ordering and checking at delivery	8
1.1 Ordering FHF02SC	8
1.2 Included items	8
1.3 Quick instrument check	9
2 Instrument principle and theory	10
2.1 Theory of operation	10
2.2 The self-test	12
2.3 Calibration	12
2.4 Application example: in situ stability check	14
2.5 Application example: non-invasive core temperature measurement	16
3 Specifications of FHF02SC	17
3.1 Specifications of FHF02SC	17
3.2 Dimensions of FHF02SC	20
4 Standards and recommended practices for use	21
4.1 Heat flux measurement in industry	21
5 Installation of FHF02SC	23
5.1 Site selection and installation	23
5.2 Electrical connection	25
5.3 Requirements for data acquisition / amplification	30
6 Maintenance and trouble shooting	31
6.1 Recommended maintenance and quality assurance	31
6.2 Trouble shooting	32
6.3 Calibration and checks in the field	33
7 Appendices	35
7.1 Appendix on wire extension	35
7.2 Appendix on standards for calibration	36
7.3 Appendix on calibration hierarchy	36
7.4 Appendix on correction for temperature dependence	37
7.5 Appendix on measurement range for different temperatures	38
7.6 EU declaration of conformity	39

List of symbols

Quantities

Heat flux
Voltage
Sensitivity
Temperature
Thermal resistance per unit area
Area
Electrical resistance
Electrical power

Symbol	Unit
Φ	W/m ²
U	V
S	V/(W/m ²)
T	°C
R _{thermal,A}	K/(W/m ²)
A	m ²
R	Ω
P	W

Subscripts

Property of heatsink
Property of heater
Property of sensor
Maximum value, specification limit

heatsink
heater
sensor
maximum

Introduction

FHF02SC is a sensor for general-purpose heat flux measurement, combined with a heater. It is used when the highest level of quality assurance is required and for special experiments. FHF02SC's thermopile sensor measures heat flux (W/m^2) through the object in which it is incorporated or on which it is mounted. Additionally the integrated type T thermocouple allows for temperature measurements. Both the thermopile and thermocouple are passive sensors; they do not require power. The combination of a heat flux sensor with a heater allows the user not only to measure a heat flux, but also to apply a heat flux.

Using FHF02SC's heat flux sensor is easy. It can be connected directly to commonly used data logging systems. The heat flux sensor output is a voltage signal that is proportional to the heat flux through the sensor: the heat flux in W/m^2 is calculated by dividing the sensor output, a small voltage, by the sensitivity. The sensitivity is provided with FHF02SC on its product certificate.

Measuring heat flux, users may wish to regularly check their sensor performance. During use, the film heater is activated to perform a self-test. The heat flux sensor response to the self-test results in a verification of sensor performance. Implicitly also cable connection, data acquisition, thermal connection of sensor to its environment and data processing are tested. Heat flux sensors are often kept installed for as long as possible. Using self-testing, the user no longer needs to take sensors to the laboratory to verify their stable performance. In a laboratory environment, using a metal heat sink, you may even perform a formal calibration. The heater has a well characterised and traceable surface area and electrical resistance.

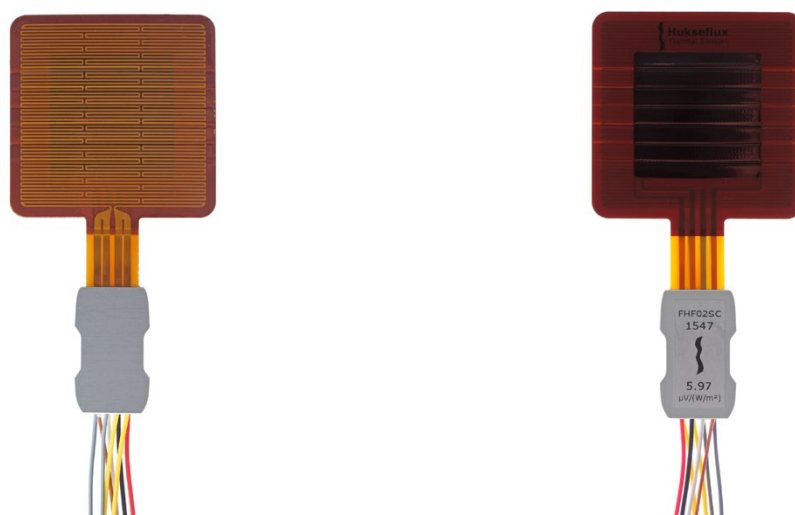

Figure 0.1 FHF02SC self-calibrating foil heat flux sensor with thermal spreaders and heater showing its heater and the reverse side. See also Figure 3.2.1 for dimensions.

A thermal spreader, which is a conductive layer covering the sensor, helps reduce the thermal conductivity dependence of the measurement. With its incorporated spreaders, the sensitivity of FHF02SC is independent of its environment. Many competing sensors do not have thermal spreaders. The passive guard area around the sensor reduces edge effects and is used for mounting. Equipped with wires with strain relief, protective covers on both sides and potted so that moisture does not penetrate the connection block, FHF02SC has proven to be very robust and stable.

FHF02SC self-calibrating foil heat flux sensor has unique features and benefits:

- heater for self-test
- low thermal resistance
- wide temperature range
- fast response time
- large guard area
- integrated type T thermocouple
- robustness, including wiring with strain relief block
- IP protection class: IP67 (essential for outdoor application)
- thermal spreader included, low thermal conductivity dependence

FHF02SC's suggested use:

- high-accuracy scientific measurement of heat flux, with a high level of data quality assurance
- study of convective heat transfer mechanisms
- calorimeter prototyping
- (zero heat flux) non-invasive core temperature measurement
- thermal conductivity test equipment



Figure 0.2 *An application of FHF02SC self-calibrating foil heat flux sensor*

Requirements for data acquisition and control:

- for heat flux: one millivolt measurement
- for heater voltage: one voltage measurement
- optional, for heater current: one current measurement or voltage measurement over a resistor
- for switching the heater current on and off: one relay with 12 VDC nominal output

FHF02SC calibration is traceable to international standards. The factory calibration method follows the recommended practice of ASTM C1130.

FHF02SC has been calibrated using a well-conducting metal heat sink, representing a typical industrial application, at 20 °C and exposing it to a conductive heat flux. When used under conditions that differ significantly from the calibration reference conditions, for example at extremely high or low temperatures, or exposed to radiative flux, the FHF02SC sensitivity to heat flux may be different than stated on the certificate. Consult Chapter 2 of this manual for solutions.

Measuring the heater power (voltage U_{heater} square divided by resistance R_{heater}), and dividing by the surface area A_{heater} , gives the applied heat flux. The heat flux sensor sensitivity S is the voltage output U_{sensor} divided by the applied heat flux.

$$S = (U_{\text{sensor}} \cdot R_{\text{heater}} \cdot A_{\text{heater}}) / U_{\text{heater}}^2 \quad (\text{Formula 0.1})$$

The user should analyse his own experiment and make his own uncertainty evaluation.

See also:

- model [FHF01](#) or [FHF02](#) for increased flexibility
- model [HFP01](#) for increased sensitivity (also consider putting two or more FHF02's in series)
- view our complete [range of heat flux sensors](#)

1 Ordering and checking at delivery

1.1 Ordering FHF02SC

The standard configuration of FHF02SC is with 2 metres of wire.

Common options are:

- with longer wire length, specify desired wire length in m

1.2 Included items

Arriving at the customer, the delivery should include:

- heat flux sensor FHF02SC with wires of the length as ordered
- product certificate matching the instrument serial number



Figure 1.2.1 The FHF02SC serial number and sensitivity are visible on the strain relief block. FHF02SC is delivered with bundled wiring.

1.3 Quick instrument check

A quick test of the instrument can be done by connecting it to a multimeter.

1. Check the sensor serial number and sensitivity on the sticker on the strain relief block against the product certificate provided with the sensor.
2. Inspect the instrument for any damage.
3. Check the electrical resistance of the sensor between the red [+] and black [-] wires. Use a multimeter at the 100 Ω range. Measure the sensor resistance first with one polarity, then reverse the polarity. Take the average value. The typical resistance of the wiring is 0.1 Ω /m. Typical resistance should be the nominal sensor resistance of 80 Ω plus 0.2 Ω for the total resistance of two wires (back and forth) for each m. Infinite resistance indicates a broken circuit; zero or a lower than 1 Ω resistance indicates a short circuit.
4. Check the electrical resistance of the thermocouple between the brown [+] and white [-] wires. Use a multimeter at the 100 Ω range. Measure the sensor resistance first with one polarity, then reverse the polarity. Take the average value. The typical resistance of the wiring is 0.1 Ω /m. Typical resistance should be the nominal thermocouple resistance of 5 Ω for plus 0.2 Ω for the total resistance of two wires (back and forth) of each m. Infinite resistance indicates a broken circuit; zero or a lower than 1 Ω resistance indicates a short circuit.
5. Check if the sensor reacts to heat: put the multimeter at its most sensitive range of DC voltage measurement, typically the 100 x 10⁻³ VDC range or lower. Expose the sensor to heat. Exposing the back side to heat should generate a positive signal between the red [+] and black [-] wires. Doing the same at the front side, reverses the sign of the output.
6. Check the electrical resistance of the heater between any of the yellow wires and any of the grey wires. Use a multimeter at the 1 k Ω range. Typical resistance should be around 100 Ω . Infinite resistance indicates a broken circuit; zero or a lower than 1 Ω resistance indicates a short circuit.
7. Check the electrical resistance between the 2 yellow wires and the 2 brown wires. These resistances should be in the 0.1 Ω /m range, so 0.2 Ω in case of the standard 2 m wire length.

2 Instrument principle and theory

FHF02SC's scientific name is heat flux sensor. A heat flux sensor measures the heat flux density through the sensor itself. This quantity, expressed in W/m^2 , is usually called "heat flux".

FHF02SC users typically assume that the measured heat flux is representative of the undisturbed heat flux at the location of the sensor. Users may also apply corrections based on scientific judgement. FHF02SC has an integrated film heater. At a regular interval the film heater is activated to perform a self-test. The self-test results in a verification of sensor performance. See the next chapters for examples how the self-test may be used. Implicitly also cable connection, data acquisition and data processing are tested.

2.1 Theory of operation

The sensitive element in the FHF02SC is a thermopile. This thermopile measures the temperature difference across the polyimide body of FHF02SC. Working completely passive, the thermopile generates a thermoelectric potential difference across the leads that is proportional to this temperature difference. The heat flux is equal to the same temperature difference divided by the effective thermal resistance of the heat flux sensor body.

Using FHF02SC is easy. For readout the user only needs an accurate voltmeter that works in the millivolt range. To convert the measured voltage U , to a heat flux Φ , the voltage must be divided by the sensitivity S , a constant that is supplied with each individual sensor:

$$\Phi = U/S \quad \text{(Formula 2.1)}$$

FHF02SC is designed such that heat flux from the back side (containing the FHF02SC heater) to the front side (marked with the sticker on the strain relief block) generates a positive voltage output signal.

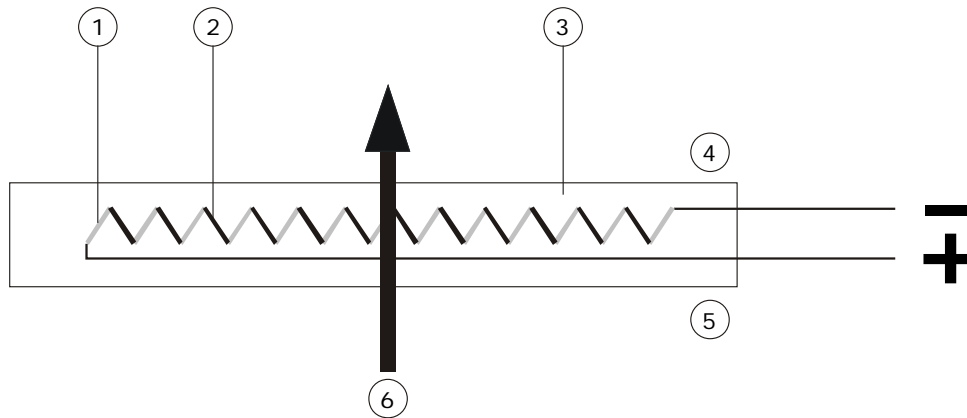

Figure 2.1 The general working principle of a heat flux sensor. The sensor inside FHF02SC is a thermopile. A thermopile consists of a number of thermocouples, each consisting of two metal alloys marked 1 and 2, electrically connected in series. A single thermocouple generates an output voltage that is proportional to the temperature difference between its hot- and cold joints. Putting thermocouples in series amplifies the signal. In a heat flux sensor, the hot- and cold joints are located at the opposite sensor surfaces 4 and 5. In steady state, the heat flux 6 is a linear function of the temperature difference across the sensor and the average thermal conductivity of the sensor body, 3. The thermopile generates a voltage output proportional to the heat flux through the sensor. The exact sensitivity of the sensor is determined at the manufacturer by calibration, and can be found on the product certificate that is supplied with each sensor.

The user should consider the conditions under which the FHF02SC is used. FHF02SC has been calibrated using a well-conducting metal heat sink, representing a typical industrial application, at 20 °C and exposing it to a conductive heat flux on the order of 600 W/m² (as opposed to radiative or convective heat flux). However, when used under conditions that differ from the calibration reference conditions, for example at extremely high or low temperatures, or exposed to radiative flux, the FHF02SC sensitivity to heat flux may differ from the one stated on the certificate. In such cases, the user may choose:

- not to use the sensitivity and only perform relative measurements / monitor changes
- reproduce the calibration conditions by mounting the sensor on or between metal foils
- design a dedicated calibration experiment, for example using a foil heater which generates a known heat flux
- coat the sensor surface (black) to absorb radiation

FHF02SC users typically assume that the measured heat flux is representative of the undisturbed heat flux at the location of the sensor. However, if perturbation of the heat flux by the sensor is suspected, users may also apply corrections based on scientific judgement.

The user should analyse his own experiment and make his own uncertainty evaluation. The FHF02SC operating temperature range is -40 to +150 °C. Prolonged exposure to temperatures near +150 °C can accelerate the aging process.

2.2 The self-test

A self-test is started by switching on FHF02SC's heater, while recording the sensor output signal and the heater power, and is finalised by switching the heater off. During the heating interval a current is fed through the film heater, which generates a known heat flux. To calculate this heat flux the heater power P_{heater} must be measured accurately. This power can be measured in several different ways;

- heater voltage and current, $P_{\text{heater}} = U_{\text{heater}} \cdot I_{\text{heater}}$ (Formula 2.2.1)
- heater voltage and known heater resistance, $P_{\text{heater}} = U_{\text{heater}}^2 / R_{\text{heater}}$ (Formula 2.2.2)
- heater current and known heater resistance, $P_{\text{heater}} = I_{\text{heater}}^2 \cdot R_{\text{heater}}$ (Formula 2.2.3)

The user must interrupt the normal measurement of the heat flux during the self-test. We recommend that the heat flux value of just before the heating interval is copied for at least 360 s.

Analysis of the heat flux sensor response to the heating, the self-test, serves several purposes:

- first, the amplitude and response time under comparable conditions are indicators of the sensor stability. See 2.4 and 2.5 for application examples.
- second, the functionality of the complete measuring system is verified. For example: a broken cable is immediately detected.
- third, under the right conditions, after taking the sensor out of its normal environment, the self-test may be used as calibration. See 2.3.1 for more details.

2.3 Calibration

FHF02SC calibration is traceable to international standards. The factory calibration method follows the recommended practice of ASTM C1130-17. When used under conditions that differ from the calibration reference conditions, the FHF02SC sensitivity to heat flux may be different than stated on its certificate.

In a typical calibration setup as shown in the next figure, the FHF02SC is positioned between an insulating material and a heatsink with the FHF02SC heater on the side of the insulating material. In such a setup, the heat losses through the insulation may be ignored. In this case all heat generated by the heater flows through the heat flux sensor to the heat sink. Measuring the heater power P_{heater} , and dividing by the surface area A_{heater} , gives the applied heat flux:

$$\Phi = P_{\text{heater}} / A_{\text{heater}} \quad (\text{Formula 2.3.1})$$

The heat flux sensor sensitivity S is the voltage output U_{sensor} divided by the applied heat flux Φ :

$$S = U_{\text{sensor}} / \Phi \quad (\text{Formula 2.3.2})$$

The reproducibility of this test is much improved when using contact material (such as glycerol or a thermal paste) between heater, sensor and heat sink.

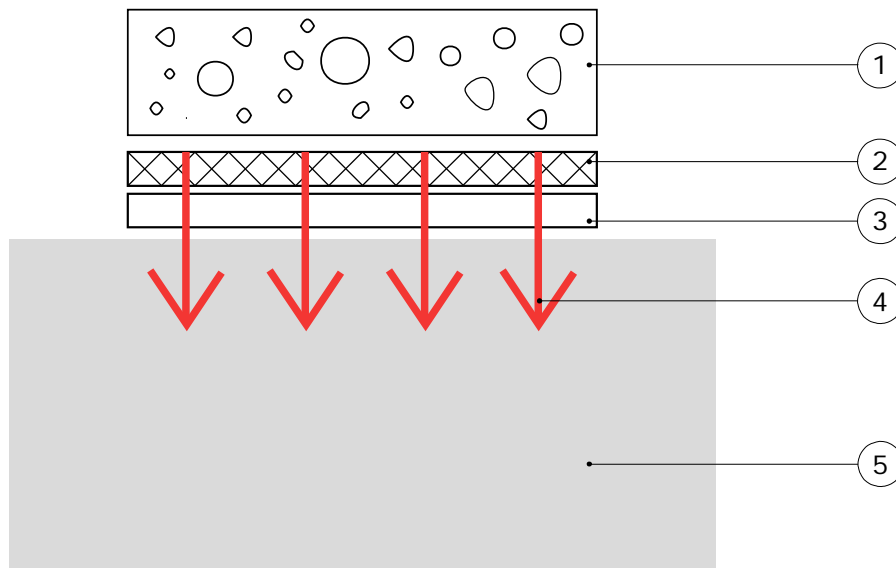

Figure 2.3.1 Calibration of FHF02SC; a typical stack used for calibration consists of a block of metal (mass > 1 kg), for example aluminium (5), the heat flux sensor (3), with heater (2) and an insulation foam (1). Under these conditions, heat losses through the insulation are negligible. Heat flux (4) flows from hot to cold.

2.4 Application example: in situ stability check

The FHF02SC heater can be used to check for stable performance of the FHF02SC at regular intervals without the need to uninstall the sensor from its application.

A typical stability check is performed based on the step response of the measured heat flux and sensor temperature to a heat flux applied by the heater. Upon installing the sensor a reference measurement should be made. A time trace of the heater power, the measured heat flux and the measured sensor temperature should be stored as reference data. Stable operation of the sensor can then be confirmed at any time by comparing to the reference measurement. The test protocol consists of the following steps:

1. Make sure that the absolute temperature is similar to that during the reference measurement.
2. Check the heater resistance stability. This can be done accurately by using the four heater wires to conduct a four-point resistance measurement.
3. Record a time trace of the heater power, the measured heat flux and the sensor temperature; the same parameters as in the reference data. Normalise the data by the heater power. Under normal circumstances (if the heater is stable) this process scales with U_{heater}^2 .
4. Compare patterns of heat flux and temperature rise and fall. In both cases relative to the values just before before heating.
 - When the signal patterns match, amplitude differences, after correction for heater power, point towards sensor instability. In this case recalibration of the sensor may be required.
 - Non-matching patterns point towards changes in sensor environment. This can for example be the result of a loss of thermal contact between sensor and object.

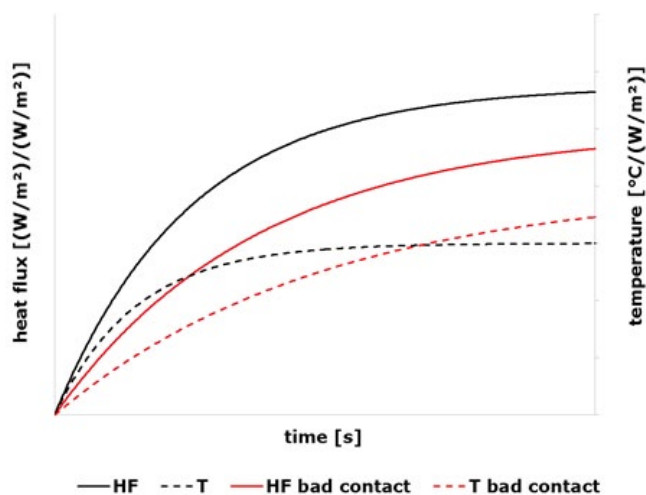

Figure 2.4.1 *In situ sensor stability check. Comparison of responses to stepwise heating relative to reference curves. Normalised to heater power (P) and relative to the heat flux and the temperature just before heating. Solid graphs show heat flux, dotted graphs show temperature. The black HF and T signals are the reference curves at good thermal contact. The sensor loses thermal contact, which results in the red responses: slower response times, lower heat flux and higher temperature rise.*

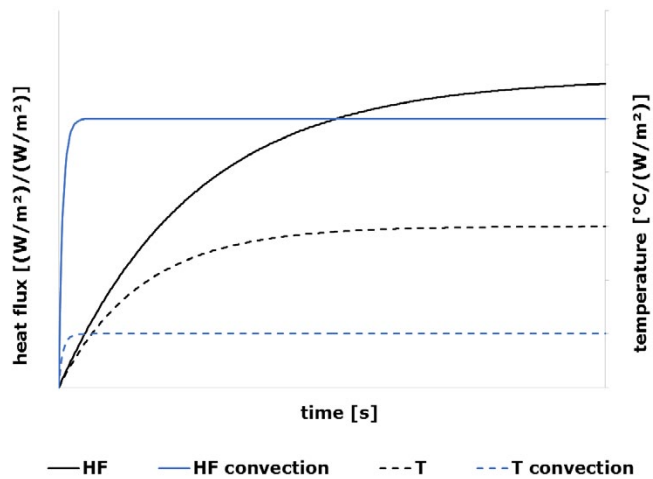

Figure 2.4.2 *In situ sensor stability check. Comparison of responses to stepwise heating relative to reference curves. Normalised to heater power (P) and relative to the heat flux and the temperature just before heating. Solid graphs show heat flux, dotted graphs show temperature. The black HF and T signals are the reference curves at zero wind speed. The sensor is exposed to convection, which results in the blue responses: faster response times at lower heat flux and lower temperature rise.*

2.5 Application example: non-invasive core temperature measurement

FHF02SC may be used for non-invasively measuring the core temperature of objects, for example of human beings.

The measurement is usually done with a sandwich of object – heat flux & temperature sensor-heater- insulation material. To determine the core temperature, the heater power should be adjusted such that the heat flux equals zero. When zero heat flux is attained, the temperature gradient equals zero and the measured temperature equals the core temperature.

To perform such a measurement a PID controller can be used to regulate the heating power. The setpoint of the PID controller should be set to zero heat flux. The PID controller can regulate the heater power either through a 0 – 12 V programmable power supply or via a solid-state relay controlled with a pulse-width-modulated signal.

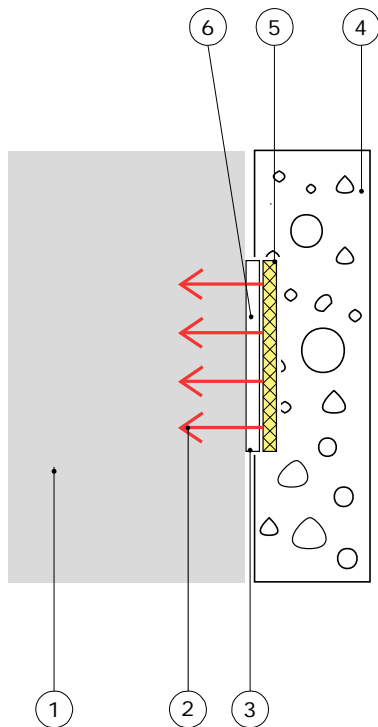

Figure 2.5.1 FHF02SC in a non-invasive core-temperature measurement. For measurement of the core temperature (1), the heater (5) is controlled to a setpoint of zero heat flux (2) measured by the heat flux sensor (3). At zero heat flux, the temperature of the core (1) and the temperature sensor (6) are equal. Insulation material (4) is attached to work at stable boundary conditions.

3 Specifications of FHF02SC

3.1 Specifications of FHF02SC

FHF02SC measures the heat flux density through the surface of the sensor. This quantity, expressed in W/m^2 , is called heat flux. Working completely passive, using a thermopile sensor, FHF02SC generates a small output voltage proportional to this flux. FHF02SC is equipped with a film heater. The heater may be used to perform an on-line self-test. Analysis of the self-test results in improved quality assurance and accuracy of the measurement. FHF02SC can only be used in combination with a suitable measurement and control system.

Table 3.1 *Specifications of FHF02SC (continued on next page)*

FHF02SC SPECIFICATIONS	
Sensor type	self-calibrating foil heat flux sensor
Sensor type according to ISO 9869	heat flow meter
Sensor type according to ASTM	heat flow sensor or heat flux transducer
Measurand	heat flux
Measurand in SI units	heat flux density in W/m^2
Measurement range	$(-10 \text{ to } +10) \times 10^3 \text{ W/m}^2$ at heat sink temperature $20 \text{ }^\circ\text{C}$ see appendix for detailed calculations
Sensitivity range	$(4 \text{ to } 8) \times 10^{-6} \text{ V/(W/m}^2)$
Sensitivity (nominal)	$5.5 \times 10^{-6} \text{ V/(W/m}^2)$
Directional sensitivity	heat flux from the bottom side to top side (side with heater) generates a positive voltage output signal
Expected voltage output	$(-80 \text{ to } +80) \times 10^{-3} \text{ V}$ turning the sensor over from one side to the other will lead to a reversal of the sensor voltage output
Measurement function / required programming	without self-test: $\Phi = U/S$ with self-test: depends on the application
Required readout	heat flux sensor: 1 x differential voltage channel or 1 single ended voltage channel, input resistance $> 10^6 \Omega$ heater: 1 x current channel and 1 x voltage channel, alternatively 1 x current channel or alternatively 1 voltage channel. Currents may be measured using a voltage channel which acts as a current measurement channel using a current sensing resistor heater: 1 x switchable 12 VDC
Optional readout	1 temperature channel
Rated load on a single wire	$\leq 1.6 \text{ kg}$
Rated bending radius	infinite, bending is not recommended
Operating temperature range	$-40 \text{ to } +150 \text{ }^\circ\text{C}$
Temperature dependence	$< 0.3 \text{ } \%/^\circ\text{C}$ (may be compensated using self-test)
Non-linearity	$< \pm 2 \text{ } \%$ ($0 \text{ to } 3.5 \times 10^3 \text{ W/m}^2$) (may be compensated using self-test)
Solar absorption coefficient	heater facing solar source: 0.75 (indication only) heater facing heat flux source: 0.58 (indication only)
Thermal conductivity dependence	negligible
Sensor length and width	$(50 \times 50) \times 10^{-3} \text{ m}$
Sensing area	$9 \times 10^{-4} \text{ m}^2$
Sensing area length and width	$(30 \times 30) \times 10^{-3} \text{ m}$

Table 3.1 Specifications of FHF02SC (started on previous page)

Passive guard area	$16 \times 10^{-4} \text{ m}^2$
Guard width to thickness ratio	20 m/m
Sensor thickness	$1.0 \times 10^{-3} \text{ m}$
Sensor thermal resistance	$37 \times 10^{-4} \text{ K/(W/m}^2\text{)}$
Sensor thermal conductivity	0.27 W/(m·K)
Response time (95 %)	12 s
Sensor resistance range	50 to 100 Ω
Required sensor power	zero (passive sensor)
Temperature sensor	type T thermocouple incorporated
Thermal spreaders	incorporated
Standard wire length	2 m
Sensor wiring	3 x copper and 1 x constantan wire, AWG 24, stranded
Heater wiring	4 x copper wire, AWG 24, stranded
Wire diameter	$1 \times 10^{-3} \text{ m}$
Marking	1 x sticker on strain relief top, showing serial number and sensitivity
IP protection class	IP67
Rated operating relative humidity range	0 to 100 %
Gross weight including 2 m wires	0.14 kg
Net weight including 2 m wires	0.07 kg
Packaging	box of 230 x 170 x 35 mm
HEATER	
heater resistance (nominal)	100 $\Omega \pm 10 \%$ (measured value supplied with each sensor in the production report)
heater rated power supply	24 VDC
heater power supply	12 VDC (nominal)
heater area	0.002062 m^2
Suggested current sensing resistor	10 $\Omega \pm 0.1 \%$, 0.25 W, < 15 ppm/°C
SELF-TEST	
Power consumption during heating interval (nominal)	1.44 W
Self-test duration	360 s (nominal)
Heating interval duration	180 s (nominal)
Settling interval duration	180 s (nominal)
INSTALLATION AND USE	
Standards governing use of the instrument	ASTM C1041 - 10 Standard Practice for In-Situ Measurements of Heat Flux in Industrial Thermal Insulation Using Heat Flux Transducers
Recommended number of sensors	2 per measurement location
Installation	see recommendations in this user manual
Bending	do not bend
Wire extension	see chapter on wire extension or order sensors with longer wires
CALIBRATION	
Calibration traceability	to SI units
Product certificate	included (showing heater nominal resistance and sensor calibration result and traceability)
Calibration method	method FHFC, according to ASTM C1130 - 17
Calibration hierarchy	from SI through international standards and through an internal mathematical procedure
Calibration uncertainty	< $\pm 5 \%$ (k = 2)

Table 3.1 *Specifications of FHF02SC (started on previous page)*

Recommended recalibration interval	2 years
Calibration reference conditions	20 °C, heat flux of 600 W/m ² , mounted on aluminium heat sink, thermal conductivity of the surrounding environment 0.0 W/(m·K)
Validity of calibration	based on experience the instrument sensitivity will not change during storage. During use the instrument “non-stability” specification is applicable. When used under conditions that differ from the calibration reference conditions, the FHF02SC sensitivity to heat flux may be different than stated on its certificate. See the chapter on instrument principle and theory for suggested solutions
Field calibration	is possible by comparison to a calibration reference sensor. Usually mounted side by side, alternative on top of the field sensor. Preferably reference and field sensor of the same model and brand. Typical duration of test > 24 h
MEASUREMENT ACCURACY	
Uncertainty of the measurement	statements about the overall measurement uncertainty can only be made on an individual basis.
VERSIONS / OPTIONS	
With longer wire length	option code = wire length in metres

3.2 Dimensions of FHF02SC

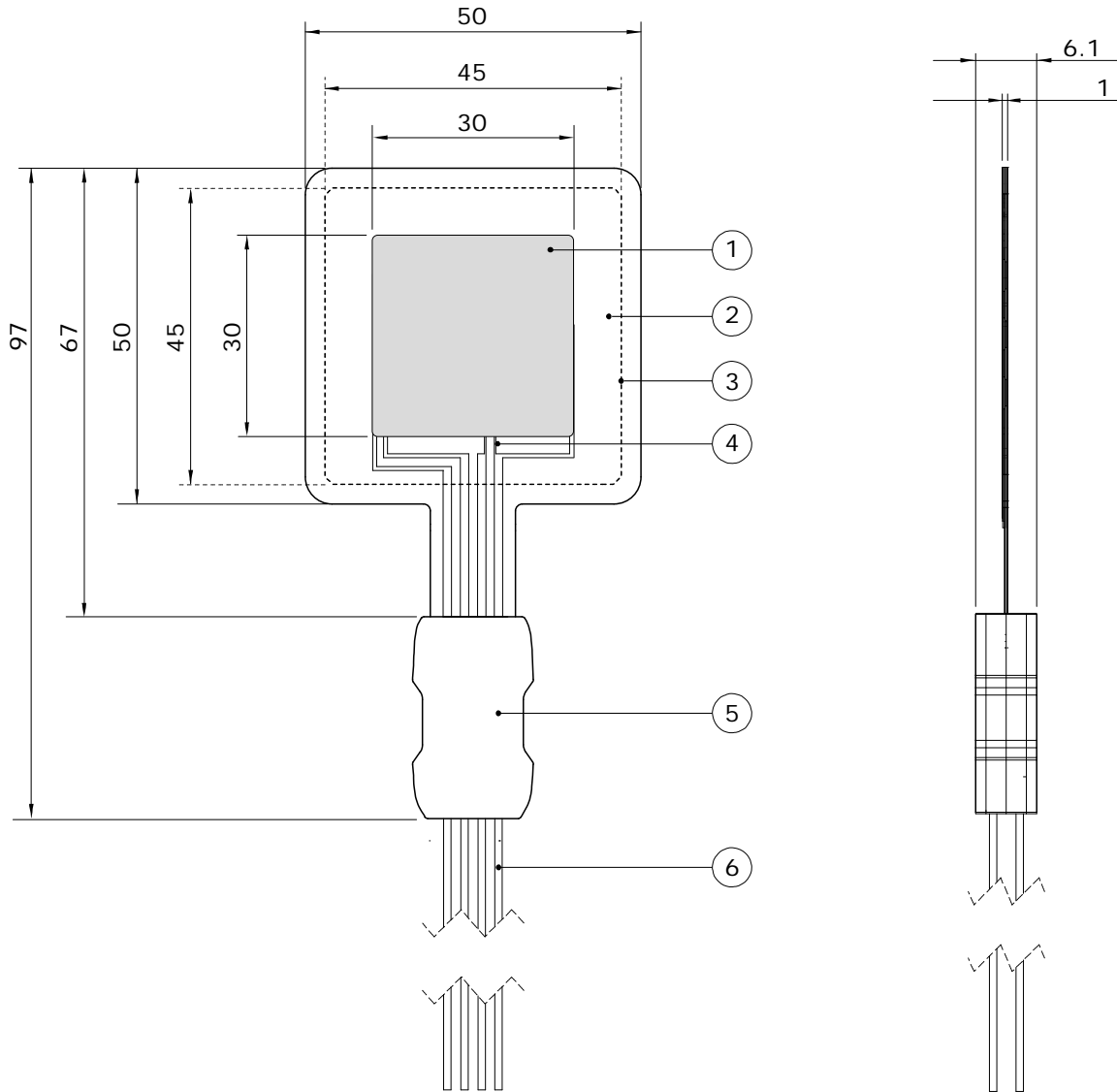

Figure 3.2.1 FHF02SC heat flux sensor; dimensions in $\times 10^{-3}$ m

- (1) sensing area with thermal spreader
- (2) passive guard
- (3) contour of the heater for self-test
- (4) type T thermocouple
- (5) strain relief block, showing serial number and sensitivity
- (6) wires, standard length 2 m

4 Standards and recommended practices for use

FHF02SC should be used in accordance with the recommended practices of ASTM.

4.1 Heat flux measurement in industry

Many FHF02SC sensors measure on industrial walls and metal surfaces, estimating the installation's energy balance and the thermal transmission of walls. Typically the total measuring system consists of multiple heat flux- and temperature sensors. In many cases heat flux sensors are used for trend-monitoring. In such cases reproducibility is more important than absolute measurement accuracy.



Figure 4.1.1 Example of a foil heat flux sensor being installed on an object. The sensor is mounted on a well prepared flat surface. Wiring must be provided with strain relief.

Table 4.1.1 contains a listing of applicable standards. We recommend users to purchase the latest version of the standard.

4.1.1 Applicable standards

Table 4.1.1 *Standards with recommendations for instrument use in industry*

STANDARDS FOR INSTRUMENT USE FOR BUILDING ENVELOPE THERMAL RESISTANCE MEASUREMENT	
ASTM STANDARD	EQUIVALENT ISO STANDARD
ASTM C1041 - 10 Standard Practice for In-Situ Measurements of Heat Flux in Industrial Thermal Insulation Using Heat Flux Transducers	Not available

5 Installation of FHF02SC

5.1 Site selection and installation

Table 5.1.1 Recommendations for installation of FHF02SC heat flux sensors

Location	<p>choose a location that is representative of the process that is analysed if possible, avoid exposure to sun, rain, etc.</p> <p>do not expose to drafts and lateral heat fluxes</p> <p>do not mount in the vicinity of thermal bridges, cracks, heating or cooling devices and fans</p> <p>NOTE: FHF02SC is not meant to be installed on curved surfaces. If installation on a curved surface is required, please consider FHF01 or FHF02 as an alternative.</p>
Performing a representative measurement / recommended number of sensors	we recommend using > 2 sensors per measurement location. This redundancy also improves the assessment of the measurement accuracy
Mounting	<p>when mounting an FHF02SC, keep the directional sensitivity in mind</p> <p>heat flux from the back side to the front side (side with sticker, logo readable) generates a positive voltage output signal</p>
Surface cleaning and levelling	create a clean and smooth surface of $(50 \times 50) \times 10^{-3}$ m
Mechanical mounting: avoiding strain on the sensor to wire transition	<p>the sensor-to-wire transition is vulnerable during installation as well as operation, the user should provide proper strain relief of the wires so that transition is not exposed to significant force</p> <p>first install the wires including strain relief and after that install the sensor</p>
Short term installation	<p>avoid any air gaps between sensor and surface. Air thermal conductivity is in the $0.02 \text{ W}/(\text{m}\cdot\text{K})$ range, while a common glue has a thermal conductivity around $0.2 \text{ W}/(\text{m}\cdot\text{K})$. A 0.1×10^{-3} m air gap increases the effective thermal resistance of the sensor by 200 %</p> <p>to avoid air gaps, we recommend thermal paste or glycerol for short term installation</p> <p>use tape to fixate the sensor on the surface. If possible, tape only over the passive guard area (the area without thermopile traces)</p> <p>use tape to fixate the strain relief block of the sensor</p> <p>usually the cables are provided with an additional strain relief, for example using a cable tie mount as in Figure 5.1.1</p>
Permanent installation	<p>for long-term installation fill up the space between sensor and object with silicone construction sealant, silicone glue or silicone adhesive, that can be bought in construction depots. Use this in combination with the spring-loaded threads</p> <p>we discourage the use of thermal paste for permanent installation because it tends to dry out. silicone glue is more stable and reliable</p>
Signal amplification	see the paragraph on electrical connection

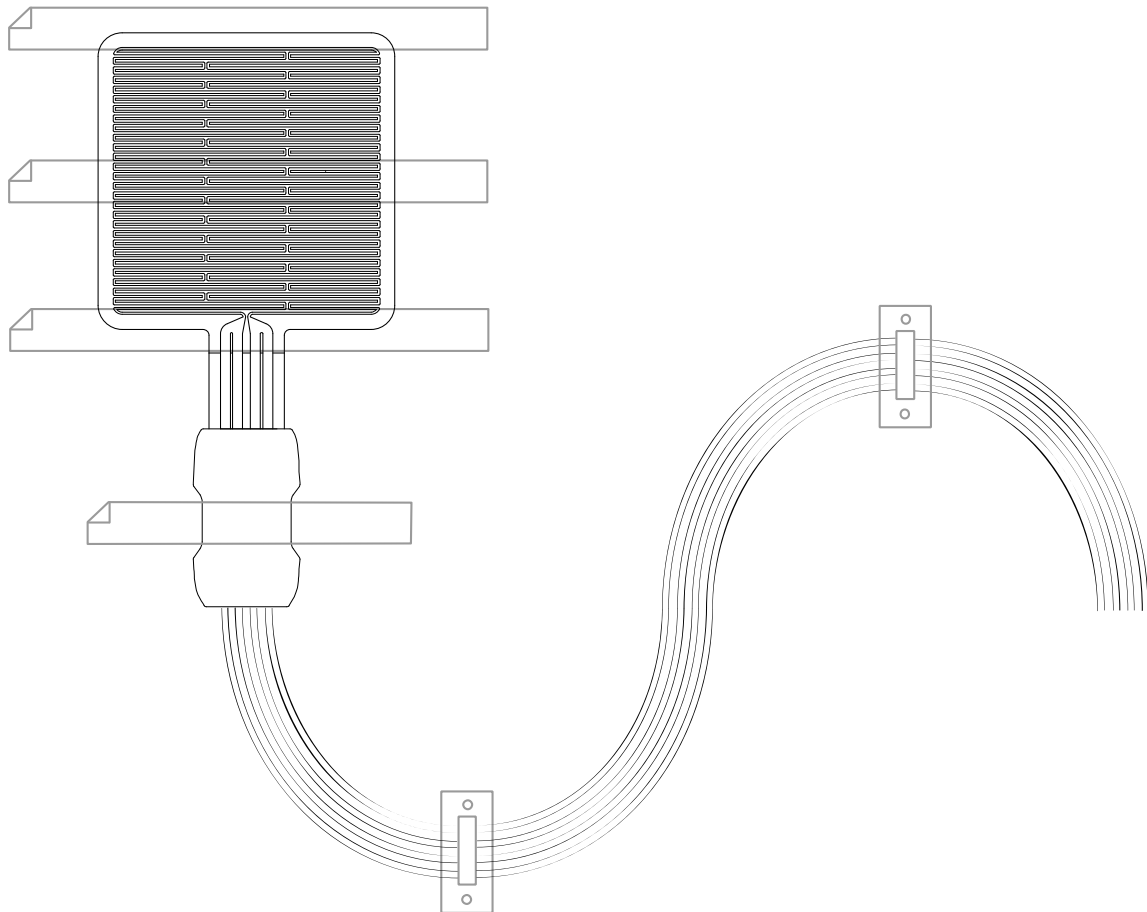

Figure 5.1.1 *Installation of FHF02SC using tape to fixate the sensor and the strain relief block. Extra strain relief of the wire is provided using cable tie mounts equipped with double sided tape as adhesive. As indicated in Table 5.1.1, tapes fixating the sensor are preferably taped over the passive guard area. In this case a third tape (in the middle) is added for extra support.*

5.2 Electrical connection

5.2.1 Normal connection

FHF02SC has two separate sets of wires, one set for the heat flux signal, and one set for the heater. The latter are yellow and grey.

To read out the heat flux sensor, FHF02SC should be connected to a measurement system, such as a voltmeter, an amplifier, a datalogger or a data-acquisition (DAQ) system. The FHF02SC electrical connections are explained in table 5.2.1.1. FHF02SC heat flux sensor is a passive sensor that does not require any power. FHF02SC's heater does require power.

Wires may pick up capacitive noise, which can lead to signal distortion. Therefore we recommend keeping the electrical connections between the measurement system and the FHF02SC as short as possible. For instructions on wire extension please refer to appendix 7.1.

Table 5.2.1.1 *The electrical connections of FHF02SC. The two yellow wires are equivalent and the two grey wires are equivalent. Together they serve to make a 4-wire connection to the heater.*

WIRE	HEAT FLUX	WIRE	HEATER
Red	heat flux signal [+]	Yellow	heater power [+]
Black	heat flux signal [-]	Yellow	heater measure [+]
White	thermocouple type T [-]	Grey	heater power [-]
Brown	thermocouple type T [+]	Grey	heater measure [-]

The sensor serial number and sensitivity are shown on the FHF02SC product certificate and on the sticker on the strain relief block.

To apply power to the FHF02SC heater, it should be connected to a 12 V power supply. To measure the power P_{heater} , the heater can be connected in several different ways, measuring:

- heater voltage and current, $P_{\text{heater}} = U_{\text{heater}} \cdot I_{\text{heater}}$ (Formula 2.2.1)
- heater voltage and known heater resistance, $P_{\text{heater}} = U_{\text{heater}}^2 / R_{\text{heater}}$ (Formula 2.2.2)
- heater current and known heater resistance, $P_{\text{heater}} = I_{\text{heater}}^2 \cdot R_{\text{heater}}$ (Formula 2.2.3)

To apply a variable controlled heat flux, the heater can either be connected via a solid state relay controlled by a pulse-width modulated (PWM) signal or to a 0 – 12 V programmable power supply. The power generated by the heater can be accurately

measured by making a four-point measurement. To this end the heater has a four-wire connection. See figure 5.2.1.1.

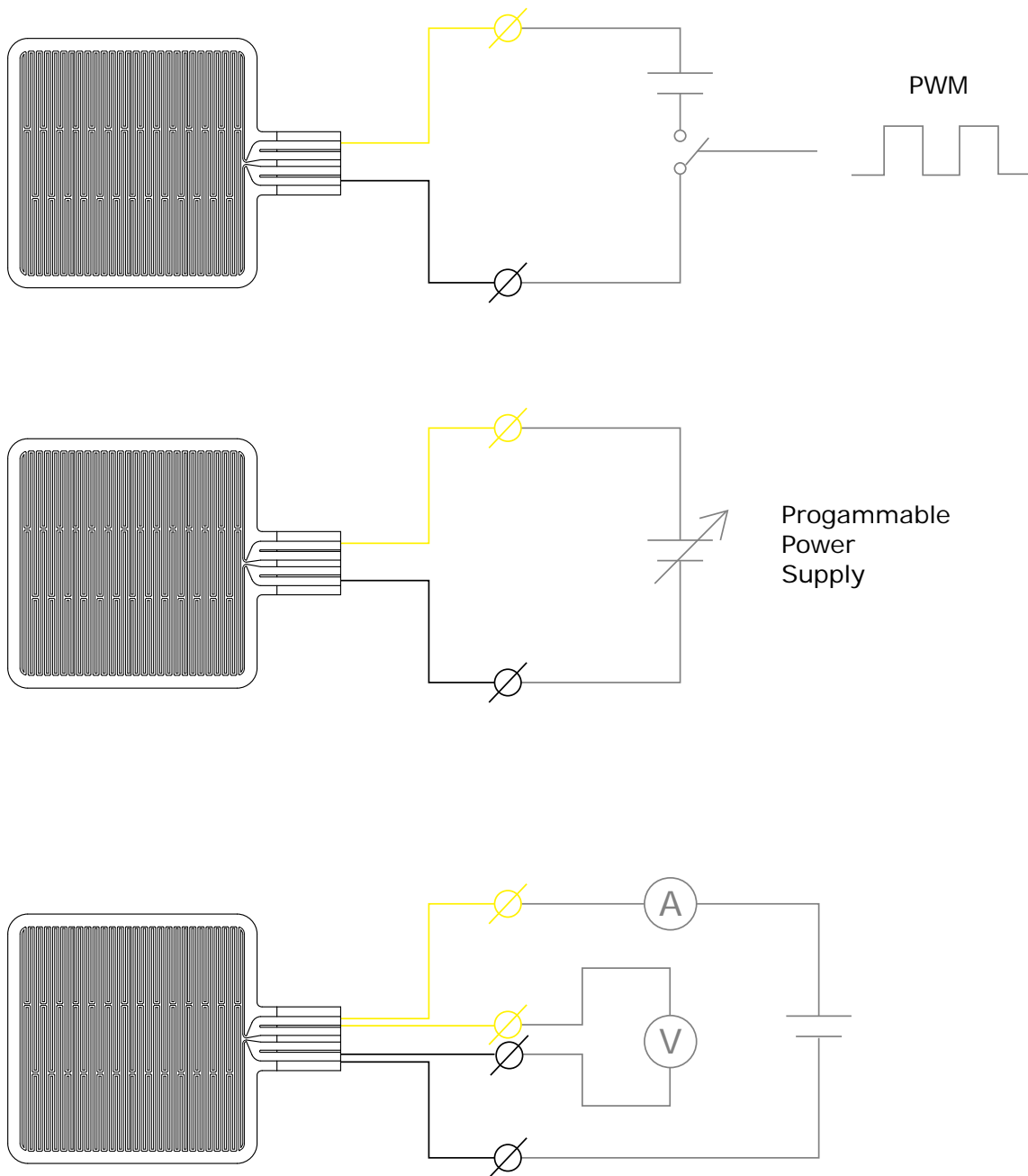

Figure 5.2.1.1 Suggested FHF02SC heater wiring. Two heater wires are used to carry the heater current, the two others are used to measure the voltage over the heater. There is no significant current flowing through voltage measurement wires so that there is no voltage drop over these wires, This “4-wire connection” measures the true voltage over the heater.

5.2.2 Increasing sensitivity by connecting multiple sensors in series

Multiple sensors may be electrically connected in series to increase sensitivity. The output signal U from two sensors connected in series is the sum of the signals U_1 and U_2 from the individual sensors:

$$U = U_1 + U_2 \quad \text{(Formula 5.2.2.1)}$$

and the resulting sensitivity S is the sum of the sensitivities S_1 and S_2 of the individual sensors:

$$S = S_1 + S_2 \quad \text{(Formula 5.2.2.2)}$$

such that the measured heat flux Φ is:

$$\Phi = U/S \quad \text{(Formula 2.1)}$$

If needed, more than two sensors may be put electrically in series to increase the sensitivity further.

Table 5.2.2.1 *The electrical connections of two FHF02SCs, 1 and 2, in series. More sensors may be added in a similar manner*

SENSOR	WIRE		MEASUREMENT SYSTEM
1	Red	signal 1 [+]	voltage input [+]
1	Black	signal 1 [-]	connected to signal 2 [+]
1	White	thermocouple type T [-]	
1	Brown	thermocouple type T [+]	
2	Red	signal 2 [+]	connected to signal 1 [-]
2	Black	signal 2 [-]	voltage input [-] or ground
2	White	thermocouple type T [-]	
2	Brown	thermocouple type T [+]	

The serial number and sensitivity of the individual sensors can be found on the FHF02SC product certificate and on the sticker on the strain relief block.

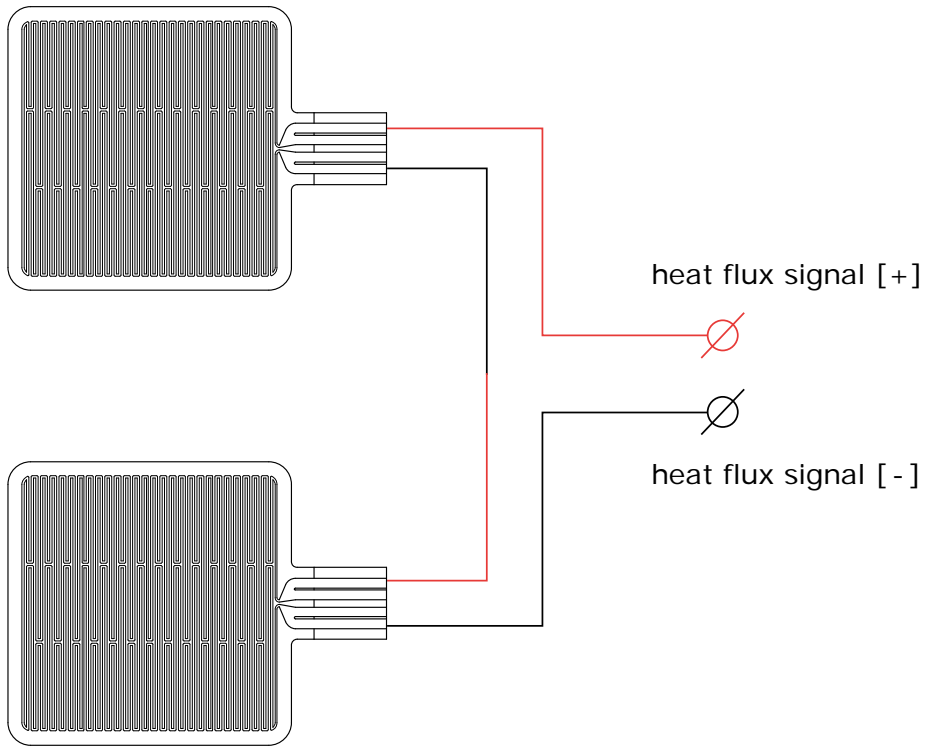

Figure 5.2.2.1 *Connecting two FHF02SC heat flux sensors in series*

5.2.3 Connection to read out half signals

See the figure below: FHF02SC can be connected to read out only the heat flux through the top half of the sensing area or through the bottom half of the sensing area. This feature may be used for quality assurance purposes; if the sensor is correctly installed we expect a constant percentage of the signal to be generated by the top – and bottom.

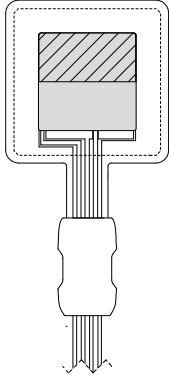

Figure 5.2.3.1 Picture of FHF02SC with top half highlighted (total sensing area is shaded grey; top half is accentuated by diagonal lines in this image)

Table 5.2.3.1 The electrical connection of FHF02SC for 100 % signal

WIRE	MEASUREMENT SYSTEM	
Red	heat flux signal [+]	voltage input [+]
Black	heat flux signal [-]	voltage input [-] or ground
White	thermocouple type T [-]	
Brown	thermocouple type T [+]	

Table 5.2.3.2 The electrical connection of FHF02SC for top 50 % signal

WIRE	MEASUREMENT SYSTEM	
Red	heat flux signal [+]	voltage input [+]
Black	heat flux signal [-]	
White	thermocouple type T [-]	
Brown	thermocouple type T [+]	voltage input [-] or ground

Table 5.2.3.3 The electrical connection of FHF02SC for bottom 50 % signal

WIRE	MEASUREMENT SYSTEM	
Red	heat flux signal [+]	
Black	heat flux signal [-]	voltage input [-] or ground
White	thermocouple type T [-]	
Brown	thermocouple type T [+]	voltage input [+]

5.3 Requirements for data acquisition / amplification

The selection and programming of dataloggers is the responsibility of the user. Please contact the supplier of the data acquisition and amplification equipment to see if directions for use with the FHF02SC are available. In case a program for similar instruments is available, this can be used. FHF02SC can be treated in the same way as other heat flux sensors and thermopile pyranometers.

Table 5.3.1 *Requirements for data acquisition and amplification equipment for FHF02SC in the standard configuration*

Capability to measure small voltage signals	preferably: $< 5 \times 10^{-6}$ V uncertainty minimum requirement: 20×10^{-6} V uncertainty (valid for the entire expected temperature range of the acquisition / amplification equipment)
Capability for the data logger or the software	to store data, and to perform division by the sensitivity to calculate the heat flux. $\Phi = U/S$ to time and control the self-test to perform comparison of test results against the acceptance limits
Capability to measure thermocouple type T	preferably: $< \pm 3$ °C uncertainty
Data acquisition input resistance	$> 1 \times 10^6 \Omega$
Open circuit detection (WARNING)	open-circuit detection should not be used, unless this is done separately from the normal measurement by more than 5 times the sensor response time and with a small current only. Thermopile sensors are sensitive to the current that is used during open circuit detection. The current will generate heat, which is measured and will appear as a temporary offset.
Capability to measure the heater voltage	the heater is powered from 12 VDC. The voltage should be measured with an uncertainty of < 1 %
Capability to measure the heater current	the heater is powered from 12 VDC, at 0.12 A. The current should be measured with an uncertainty of < 1 % a $10 \Omega \pm 0.1\%$ current sensor resistor is often used.
Capability to switch the heater on and off	a relay must be used, capable of switching the required 12 VDC at 0.12 A (nominal values).

6 Maintenance and trouble shooting

6.1 Recommended maintenance and quality assurance

FHF02SC measures reliably at a low level of maintenance. Unreliable measurement results are detected by scientific judgement, for example by looking for unreasonably large or small measured values. The preferred way to obtain a reliable measurement is a regular critical review of the measured data, preferably checking against other measurements.

Table 6.1.1 *Recommended maintenance of FHF02SC. If possible the data analysis is done on a daily basis*

MINIMUM RECOMMENDED HEAT FLUX SENSOR MAINTENANCE			
	INTERVAL	SUBJECT	ACTION
1	1 week	data analysis	compare measured data to the maximum possible or maximum expected heat flux, to other measurements from other redundant instruments and to data previously measured under identical circumstances. Look for any patterns and events that deviate from what is normal or expected. Compare to acceptance intervals. Analyse the self-test measurement results. Compare to acceptance intervals.
2	6 months	inspection	inspect wire quality, inspect mounting, inspect location of installation look for seasonal patterns in measurement data and results of the self-test
3	2 years	recalibration	recalibration by comparison to a calibration standard instrument in the field, see following paragraphs. recalibration by the sensor manufacturer
4		lifetime assessment	judge if the instrument will be reliable for another 2 years, or if it should be replaced

6.2 Trouble shooting

Table 6.2.1 *Trouble shooting for FHF02SC*

General	<p>Inspect the sensor for any damage. Inspect the quality of mounting / installation. Inspect if the wires are properly attached to the data logger.</p> <p>Check the condition of the wires.</p> <p>Check the datalogger program in particular if the right sensitivity is entered. FHF02SC sensitivity and serial number are shown on the product certificate and on the sticker on the strain relief block.</p> <p>Check the electrical resistance of the sensor between the black [-] and red [+] wires. Use a multimeter at the 100 Ω range. Measure the sensor resistance first with one polarity, then reverse the polarity. Take the average value. The typical resistance of the wiring is 0.1 Ω/m. Typical resistance should be the nominal sensor resistance of 80 Ω plus 0.2 Ω for the total resistance of two wires (back and forth) of each m. Infinite resistance indicates a broken circuit; zero or a lower than 1 Ω resistance indicates a short circuit.</p> <p>Check the electrical resistance of the film heater between the wires of the heater. You may use a 4-wire connection. Use a multimeter at the 1000 Ω range. Typical resistance should be the typical heater resistance of 100 $\Omega \pm 10\%$. Infinite resistance indicates a broken circuit; zero or a lower than 1 Ω resistance indicates a short circuit.</p> <p>Check the sensor serial number, and sensitivity on the certificate.</p> <p>Check the heater resistance value in Ω on the product certificate.</p>
The sensor does not give any signal	<p>Check if the sensor reacts to heat: put the multimeter at its most sensitive range of DC voltage measurement, typically the 100 x 10⁻³ VDC range or lower. Expose the sensor heat or activate the FHF02SC heater by putting 9 to 12 VDC across the yellow and gray wires. The signal should read > 2 x 10⁻³ V now.</p> <p>Exposing the back side to heat should generate a positive signal between the red [+] and black [-] wires, doing the same at the front side, the sign of the output reverses.</p> <p>Check the data acquisition by replacing the sensor with a spare unit.</p>
The sensor signal is unrealistically high or low	<p>Check the wire condition looking for wire breaks.</p> <p>Check the data acquisition by applying a 1 x 10⁻⁶ V source to it in the 1 x 10⁻⁶ V range. Look at the measurement result. Check if it is as expected.</p> <p>Check the data acquisition by short circuiting the data acquisition input with a 10 Ω resistor. Look at the output. Check if the output is close to 0 W/m².</p>
The sensor signal shows unexpected variations	<p>Check the presence of strong sources of electromagnetic radiation (radar, radio).</p> <p>Check the condition of the sensor wires.</p> <p>Check if the wires are not moving during the measurement.</p>

6.3 Calibration and checks in the field

The recommended calibration interval of heat flux sensors is 2 years.

Recalibration of field heat flux sensors is ideally done by the sensor manufacturer. You may also calibrate by yourself following Chapter 2.3.

On-site field calibration is possible by comparison to a calibration reference sensor. Usually mounted side by side, alternatively mounted on top of the field sensor.

Hukseflux main recommendations for field calibrations are:

- 1) to compare to a calibration reference of the same brand and type as the field sensor
- 2) to connect both to the same electronics, so that electronics errors (also offsets) are eliminated
- 3) to mount all sensors on the same platform, so that they have the same body temperature
- 4) typical duration of test: > 24 h
- 5) typical heat fluxes used for comparison: > 600 W/m²
- 6) to correct deviations of more than $\pm 20\%$. Lower deviations should be interpreted as acceptable and should not lead to a revised sensitivity

Users may also design their own calibration experiment, for example using a well characterised foil heater.

7 Appendices

7.1 Appendix on wire extension

FHF02SC is equipped with four wires. Keep the distance between data logger or amplifier and sensor as short as possible. Wires may act as a source of distortion by picking up capacitive noise. In an electrically “quiet” environment the FHF02SC cable may be extended without problem to 100 metres. If done properly, the sensor signal, although small, will not significantly degrade because the sensor resistance is very low (which results in good immunity to external sources) and because there is no current flowing (so no resistive losses). Wire and connection specifications are summarised below.

Standard wire length is 2 m. It is possible to order FHF02SC with longer wire lengths.

Table 7.1.1 Preferred specifications for wire extension of FHF02SC

Wire	heat flux and temperature sensor: 3 x copper and 1 x constantan wire, AWG 24, stranded heater: 4 x copper wire, AWG 24, stranded
Extension sealing	make sure any connections are sealed against humidity ingress
Conductor resistance	< 0.1 Ω /m (copper wire)
Outer diameter	1 x 10 ⁻³ m
Length	cables should be kept as short as possible, in any case the total cable length should be less than 100 m
Connection	either use gold plated waterproof connectors, or solder the new wire conductors and shield to those of the original sensor wire, and make a waterproof connection using heat-shrink tubing with hot-melt adhesive when using connectors, use dedicated type T thermocouple connectors for extending the thermocouple wires

7.2 Appendix on standards for calibration

The standard ASTM C1130 - 17 Standard Practice for Calibrating Thin Heat Flux Transducers specifies in chapter 6 that a guarded hot plate, a heat flowmeter, a hot box or a thin heater apparatus are all allowed. Hukseflux employs a thin heater apparatus, uses a linear function according to X1.1 and uses a nominal temperature of 20 °C, in accordance with X2.2.

The Hukseflux FHFC method relies on a thin heater apparatus according to principles as described in paragraph 4 of ASTM C1114 - 06, used in the single sided mode of operation described in paragraph 8.2 and in ASTM C1044 - 12.

ISO does not have a dedicated standard practice for heat flux sensor calibration. We follow the recommended practice of ASTM C1130 - 17.

Table 7.2.1 Heat flux sensor calibration according to ISO and ASTM.

STANDARDS ON INSTRUMENT CLASSIFICATION AND CALIBRATION	
ISO STANDARD	EQUIVALENT ASTM STANDARD
no dedicated heat flux calibration standard available.	ASTM C1130 - 17 Standard Practice for Calibrating Thin Heat Flux Transducers ASTM C 1114 - 06 Standard Test Method for Steady-State Thermal Transmission Properties by Means of the Thin-Heater Apparatus ASTM C1044 - 16 Standard Practice for Using a Guarded-Hot-Plate Apparatus or Thin-Heater Apparatus in the Single-Sided Mode

7.3 Appendix on calibration hierarchy

FHF02SC factory calibration is traceable from SI through international standards and through an internal mathematical procedure that corrects for known errors. The formal traceability of the generated heat flux is through voltage and current to electrical power and electric power and through length to surface area.

The Hukseflux FHFC method follows the recommended practice of ASTM C1130 - 17. It relies on a thin heater apparatus according to principles as described in paragraph 4 of ASTM C1114 - 06, in the single sided mode of operation described in paragraph 8.2 and in ASTM C1044 - 16. The method has been validated in a first-party conformity assessment, by comparison to calibrations in a guarded hot plate.

7.4 Appendix on correction for temperature dependence

The sensitivity of a FHF02SC depends on the temperature of the sensor. The temperature dependence of the FHF02SC is specified as $< 0.3 \text{ \%/}^\circ\text{C}$. Characterisation of FHF02SCs that we produced so far gives consistent values of $+0.25 \text{ \%/}^\circ\text{C}$.

The calibration reference temperature is $20 \text{ }^\circ\text{C}$.

Users that measure at temperatures that deviate much from $20 \text{ }^\circ\text{C}$, or users that measure over a wide range of temperatures, may wish to correct for this temperature dependence.

To correct for the temperature dependence of the sensitivity, use the measurement function

$$\Phi = U / (S \cdot (1 + 0.0025 \cdot (T - 20))) \quad (\text{Formula 7.4.1})$$

with Φ the heat flux in W/m^2 , U the FHF02 voltage output in V , S the sensitivity in $\text{V}/(\text{W/m}^2)$ at $20 \text{ }^\circ\text{C}$ and T the FHF02SC temperature.

S is shown on the product certificate and on the sticker on the strain relief block.

7.5 Appendix on measurement range for different temperatures

The measurement range of FHF02SC is specified as $(-10 \text{ to } +10) \times 10^3 \text{ W/m}^2$ at $20 \text{ }^\circ\text{C}$ heat sink temperature. This is a very conservative specification.

In reality, the maximum temperature of $+150 \text{ }^\circ\text{C}$ is the limiting specification. The sensor temperature T in $^\circ\text{C}$ in a specific application depends on the heatsink temperature T_{heatsink} in $^\circ\text{C}$, the heat flux Φ in W/m^2 and the thermal resistance per unit area $R_{\text{thermal,A}}$ of the sensor in $\text{K}/(\text{W/m}^2)$.

$$T = T_{\text{heatsink}} + \Phi \cdot R_{\text{thermal,A}} \quad (\text{Formula 7.5.1})$$

This means the measurement range is lower for higher heat sink temperatures.

$$\Phi_{\text{maximum}} = (150 - T_{\text{heatsink}}) / R_{\text{thermal,A}} \quad (\text{Formula 7.5.2})$$

Table 7.5.1 shows measurement ranges for different heat sink temperatures. For applications where the sensor is not mounted on a heatsink, use the ambient temperature instead of heatsink temperature.

Table 7.5.1 *measurement range for different heat sink temperatures*

HEATSINK TEMPERATURE	MEASUREMENT RANGE
20 $^\circ\text{C}$	$43 \times 10^3 \text{ W/m}^2$
40 $^\circ\text{C}$	$37 \times 10^3 \text{ W/m}^2$
60 $^\circ\text{C}$	$30 \times 10^3 \text{ W/m}^2$
80 $^\circ\text{C}$	$23 \times 10^3 \text{ W/m}^2$
100 $^\circ\text{C}$	$17 \times 10^3 \text{ W/m}^2$

7.6 EU declaration of conformity



We, Hukseflux Thermal Sensors B.V.
Delftechpark 31
2628 XJ Delft
The Netherlands

in accordance with the requirements of the following directive:

2014/30/EU The Electromagnetic Compatibility Directive

hereby declare under our sole responsibility that:

Product model: FHF02SC
Product type: Self-calibrating foil heat flux sensor

has been designed to comply and is in conformity with the relevant sections and applicable requirements of the following standards:

Emission: EN 61326-1 (2006)
Immunity: EN 61326-1 (2006)
Emission: EN 61000-3-2 (2006)
Emission: EN 61000-3-3 (1995) + A1 (2001) + A2 (2005)
Report: 08C01340RPT01, 06 January 2009

A handwritten signature in blue ink, appearing to be 'Eric Hoeksema'.

Eric HOEKSEMA
Director
Delft
December 20, 2017

