

# DR30-D1

Next level digital first class pyrhelimeter, with heating and tilt sensor

*DR30 is a high-accuracy digital direct (normal incidence) solar radiation sensor. The scientific name of this instrument is pyrhelimeter. DR30 complies with the first class specifications of the ISO 9060 standard and the WMO Guide. This next level pyrhelimeter has superior window heating that leads to high data availability, and an internal tilt sensor to check tracker performance.*



**Figure 1** DR30-D1 next level digital first class pyrhelimeter, with heating and tilt sensor



**Figure 2** the importance of heating: tracker-mounted operation of DR30 pyrhelimeter (on the right) compared to a non-heated instrument (on the left). The data availability of the non-heated instrument suffers in almost all environments due to morning dew, rime and frost.

## Introduction

Welcome to the next level in solar radiation monitoring! The all-digital DR30-D1 pyrhelimeter offers the highest accuracy and highest data availability, featuring window heating at low offsets. At the same heating power, the heating has been improved with a factor 4, at a 4 times lower offset! DR30 also offers on-board tilt and humidity sensors. It is applied in high accuracy measurement of the solar radiation received by a plane surface from a 5 ° full field of view angle. This quantity, expressed in W/m<sup>2</sup>, is called "direct" solar radiation or DNI (direct normal irradiance). It is necessary to keep the instrument pointed at the sun by using a two-axis tracker.

## Heated for high data availability

High data availability is attained by heating of the front window. This suppresses dew and frost deposition.

- low power consumption: DR30 needs only 2 W to keep its window free from dew and frost

## Remote sensor diagnostics

In addition to solar irradiance, DR30 outputs sensor diagnostics such as:

- tilt angle
- internal humidity
- heater current

Remote diagnostics permits real-time status monitoring, reducing the need for (un)scheduled field inspections.

## Liabilities covered: test certificates

Each next level digital DR30 pyrhelimeter is supplied with test results for the individual instrument:

- sensitivity
- response time
- temperature response
- tilt angle measurement

### DR30 use

DR30 pyrheliometer is used in tracker-mounted operation. DR30 can be connected directly to commonly used data logging systems. It offers a digital output via Modbus RTU over 2-wire RS-485.

### DR30 design

The pyrheliometer features a precision ground and polished quartz window, a compact sized collimated tube and a thermopile sensor with black coated surface.

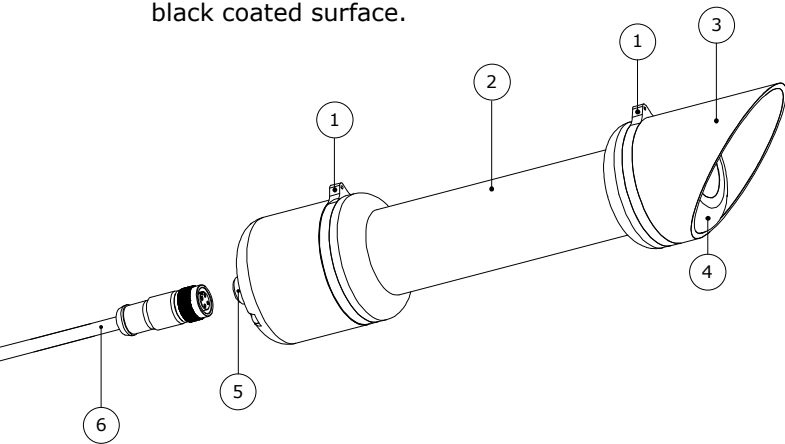

**Figure 3** overview of DR30:  
(1) sights, (2) aperture tube, (3) protection cap, (4) window assembly with heater, (5) connector, (6) cable

### Suggested use

- solar energy surveys
- solar resource assessments
- meteorological networks
- sites with dew and frost problems

### Hukseflux Sensor Manager software

For communication between a PC and DR30, the Hukseflux Sensor Manager software is included. It allows the user to plot and export data, and change the DR30 Modbus address and communication settings. Also, the digital outputs may be viewed for sensor diagnostics.

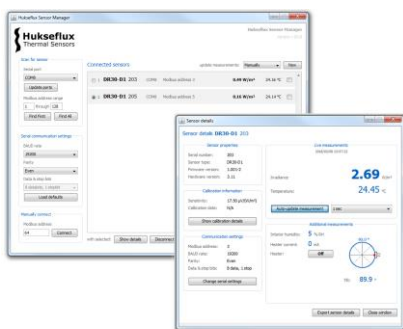

**Figure 4** user interface of the Sensor Manager, showing sensor diagnostics

### DR30-D1 specifications

Measurand	direct solar radiation
ISO classification	first class pyrheliometer
Calibration uncertainty	< 1.2 % (k = 2)
Measurand	sensor tilt angle
Tilt measurement uncertainty	± 1 ° (0 to 180 °)
Heating	included
Response time (95 %)	4 s
Full field of view angle	5 °
Slope angle	1 °
Power consumption	
- standard operating mode	2 W
- low power operating mode	0.1 W
Zero offset	< ± 1 W/m <sup>2</sup>
Calibration traceability	to WRR
Spectral range	200 to 4000 x 10 <sup>-9</sup> m
Rated operating temperature range	-40 to +80 °C
Temperature response	< ± 0.4 % (-30 to +50 °C)
Temperature response test of individual instrument	report included
Tilt sensor test of individual instrument	report included
Rated operating voltage	7 to 30 VDC
Standard cable length	5 m

### Digital output

Output	- irradiance in W/m <sup>2</sup> - instrument body temperature in °C - tilt angle in ° - internal humidity in % - heater current in mA
Communication protocol	Modbus / over 2-wire RS-485
Transmission mode	RTU

### Options

- longer cable; 10 and 20 metres
- 20 metres extension cable with 2 connectors

### See also

- **DR20-A1** and **DR15-A1** analogue spectrally flat Class A & B pyrheliometers, with heating
- view our complete **product range of sensors**



**Figure 5** DR30 digital pyrheliometer front view

### DR30 user benefits

Using DR30 digital pyrhelimeter offers significant benefits over the use of competing models. The all-digital DR30 pyrhelimeter offers the highest accuracy and highest data availability, featuring heating at low offsets, and on-board tilt and humidity sensors. The advantages of having a heater and a tilt sensor are demonstrated in the following graphs:

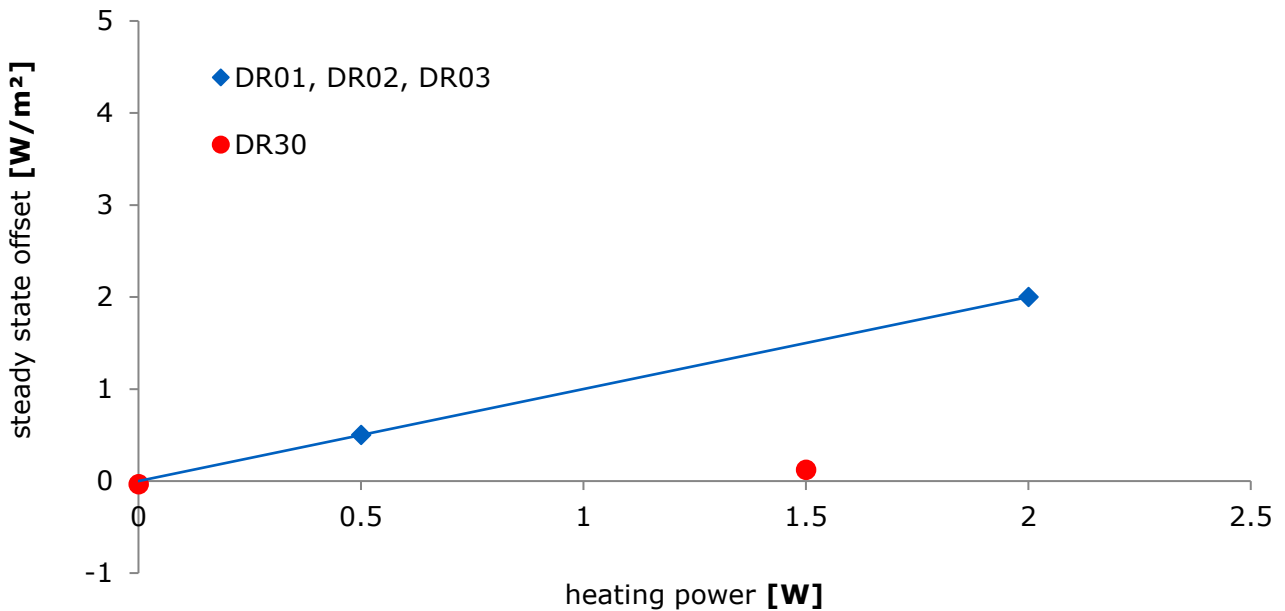

**Figure 6** the offset of DR30 when heating is much improved relative to the older DR01, DR02 and DR03 models. DR30 has a 1.5 W heater and produces a negligible offset. The older models had offsets of the order of 2  $W/m^2$  at the same heating levels. In addition, the temperature of the front window of DR30 is 4 times higher than that of the older models, at the same heating power.

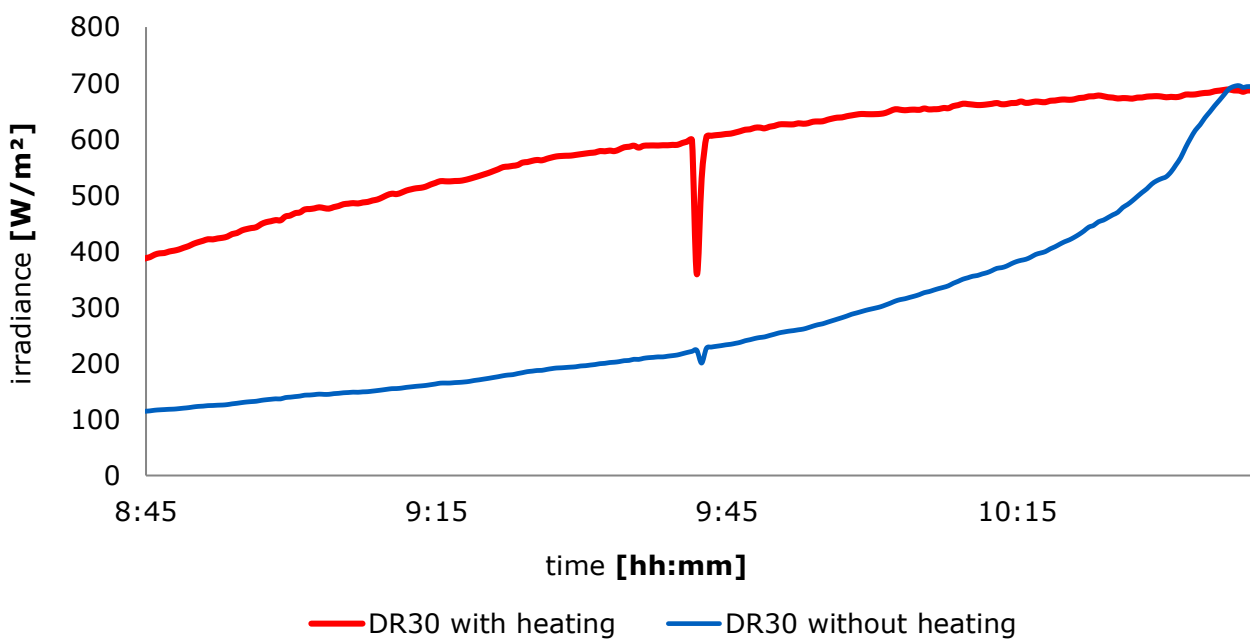

**Figure 7** comparison of the measured data with and without heating on a typical winter morning. The unheated DR30 has dew on its front window and strongly underestimates the incoming irradiance. At around 10:30 the dew evaporates. Real measured data from Delft, the Netherlands.

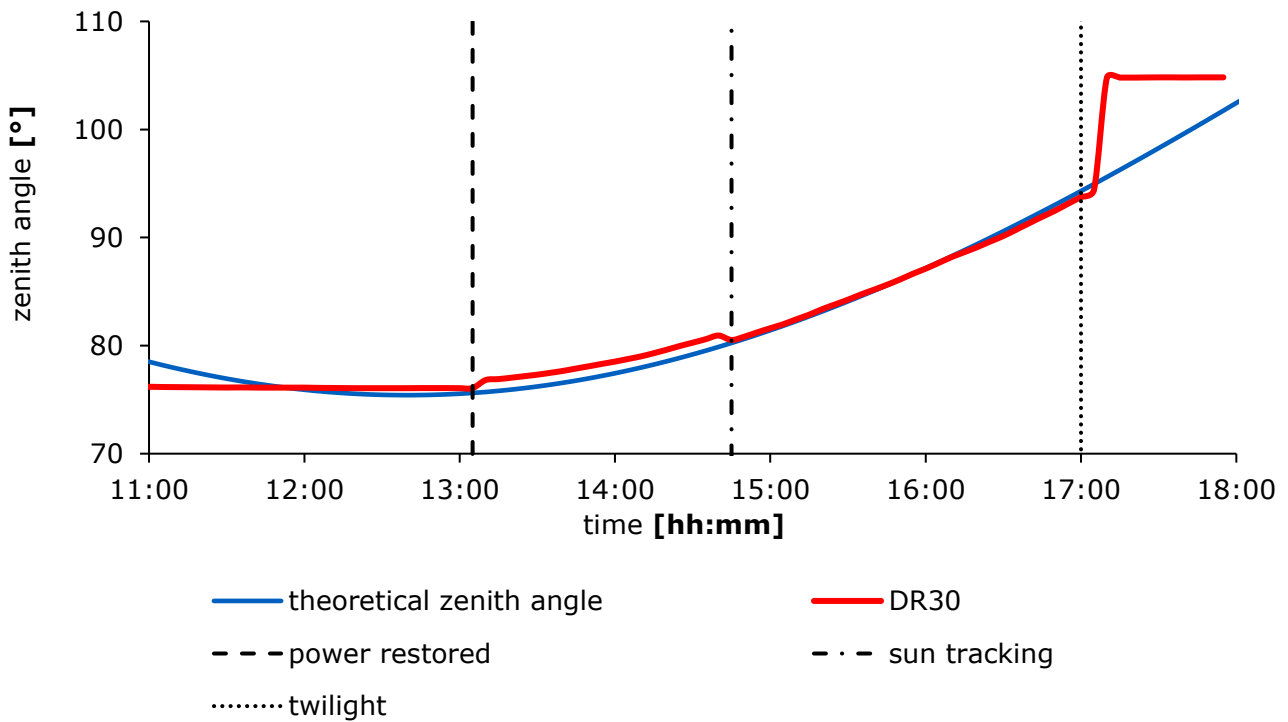

**Figure 8** example of use of the DR30 tilt sensor for tracker performance monitoring: the red line is the output of the DR30 tilt sensor, the blue line the theoretical zenith angle. There is a power failure before 13:00, at that time power is restored. Tracking between 13:00 and 15:00 is under cloudy conditions, based on GPS information only and slightly off. Tracking from 15:00 onwards is under sunny conditions and based on the tracker's sun sensor. The tracker moves to its rest position shortly after 17:00. Real measured data from Delft, the Netherlands.

### Uncertainty evaluation

The uncertainty of a measurement under outdoor conditions depends on many factors. Guidelines for uncertainty evaluation (according to the "Guide to Expression of Uncertainty in Measurement" or GUM) can be found in our manuals. We provide spreadsheets to assist in the process of uncertainty evaluation of your measurement.

### About Hukseflux

Hukseflux Thermal Sensors offers measurement solutions for the most challenging applications. We design and supply sensors as well as test & measuring systems, and offer related services such as engineering and consultancy. Our main area of expertise is measurement of heat transfer and thermal quantities such as solar radiation, heat flux and thermal conductivity. Hukseflux is ISO 9001 certified. Hukseflux sensors, systems and services are offered worldwide via our office in Delft, the Netherlands and local distributors.



**Figure 9** DR30 digital pyrheliometer side view

Interested in this product?  
E-mail us at: [info@hukseflux.com](mailto:info@hukseflux.com)