

Pyranometer physics: why two domes?

Pyranometers are accurate instruments to measure solar irradiance. Have you ever wondered why thermopile pyranometers have one or two domes? This note explores the physics of pyranometers: how do thermopile pyranometers work and why are these domes necessary?

Introduction

All thermopile pyranometers are thermal instruments: they derive their signal from a temperature difference in the sensor. In other words: thermopile pyranometers are just fancy thermometers. The trick is to make sure the pyranometer is only sensitive to solar radiation.

This note attempts to give you an understanding of the pyranometer working principle and, in particular, an answer to the question: why do accurate pyranometers use two glass domes?

Pyranometer basics

As the name implies, the central element in any thermopile pyranometer is the thermopile. A thermopile is a stack of two different conducting materials. It generates a voltage in response to a temperature difference between the 'hot' and the 'cold' side of the stack. This phenomenon is known as the 'thermoelectric effect', expressed by the different Seebeck coefficients of the two materials.

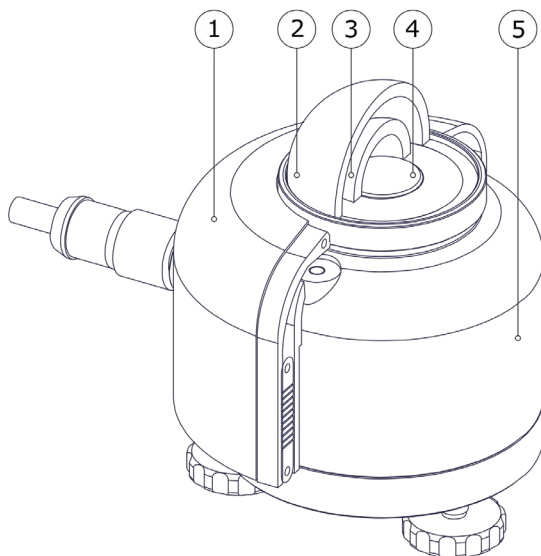

Figure 1 essential parts of a typical thermopile pyranometer: sunscreen (1), outer dome (2), inner dome (3), thermopile with sensor surface (4) and aluminium sensor body (5)



Figure 2 pyranometers can be used to monitor the performance of photovoltaic systems

The cold side of the thermopile is attached to the sensor body, while the hot side, the 'sensor surface', is coated with a black, radiation-absorbing coating and exposed to the sun. Solar radiation will heat up the sensor surface, while the cold side is kept at ambient temperature via the thermal connection to the sensor body. This temperature difference is what generates the sensor signal.

The rest of the pyranometer is designed to ensure that all other thermal exchange is reduced as much as possible. Only solar radiation should be allowed to heat up the sensor surface. In this note, we will focus on one unwanted thermal exchange process: the exchange of infrared radiation with the cold sky.

Pyranometer performance is standardized in ISO 9060^[1], based on several criteria. The offset signal caused by infrared exchange is one of these criteria, known as 'zero offset a'. For accurate measurements, it is important to reduce this offset as much as possible.

This note will provide insight in how we achieve a low 'zero offset a' in the Hukseflux range of next-level pyranometers: SR05, SR15 and SR30.

Introducing the first dome

A typical black coating used in pyranometer construction has a flat spectral sensitivity in the range of 200 nm (ultraviolet) to 50 μm (far infrared). Therefore, a bare thermopile pyranometer would be very sensitive to non-solar infrared radiation. In particular, the sensor surface, which has a temperature close to the ambient air temperature, would exchange infrared radiation with the cold sky above.

On a clear, cloudless day, the atmosphere can be estimated by a black body with a temperature of $-20\text{ }^\circ\text{C}$, meaning that the infrared exchange between the sensor and sky will actually cool down the sensor surface. In response, the sensor will underestimate the solar irradiance. We call this the 'longwave sensitivity' of the sensor, analogous to the desired shortwave sensitivity for solar radiation.

This effect is especially visible on clear, cloudless nights where pyranometers typically report a negative sensor signal: the so-called 'zero offset a'. Note that this offset is **always present**: during the day it is buried beneath the positive signal generated by solar irradiance. The black body temperature of a clouded sky is much closer to the air temperature at ground level, such that this effect is much smaller on clouded days and nights.

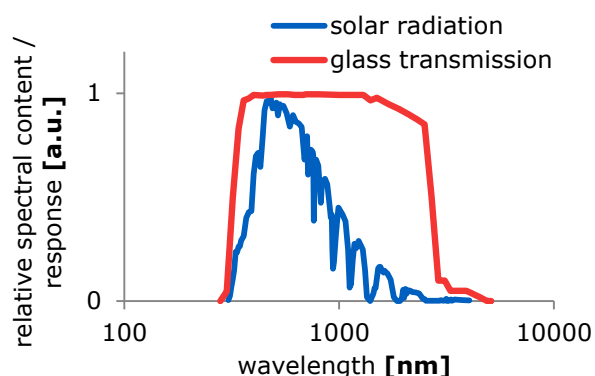

Figure 3 spectral transmission of glass compared to the solar spectrum at surface level. Thermal radiation from terrestrial or atmospheric sources is found around $10\text{ }\mu\text{m}$ and blocked by glass.

A single glass dome, as mounted on second class pyranometers like the SR05, is the first line of defence against this offset. Glass transmits

radiation with a near-flat spectral sensitivity in the 285-3000 nm range, while absorbing radiation in most of the infrared range. The dome will then act as a radiation shield for infrared radiation: thermal exchange will now take place between sky and dome and between dome and sensor surface separately. Box 1 describes these physics in more detail.

A dome provides more advantages. Firstly, thermal conduction between the sensor body and the dome also raises the dome temperature, reducing thermal exchange even further. Secondly, a dome also protects the sensor against the elements, in particular against convective cooling by wind.



Figure 4 SR05 is a second class pyranometer. It has a single glass dome to insulate the sensor surface from infrared thermal exchange with the colder sky. In addition, the dome protects the sensor against the elements.

More is better?

As shown in Box 1, the insulation against infrared thermal exchange increases with the number of domes. That's why our first class pyranometers like the SR15 are equipped with two domes instead of one.

However, every added dome yields a lower increase in infrared insulation than the previous one: an example of the law of diminishing returns. Since domes are expensive, it is not effective to use more than two domes. Moreover, other problems like reduced transmission and increased lens effect complicate the construction of an accurate pyranometer with more than two domes.

Box 1 the dome as a radiation shield

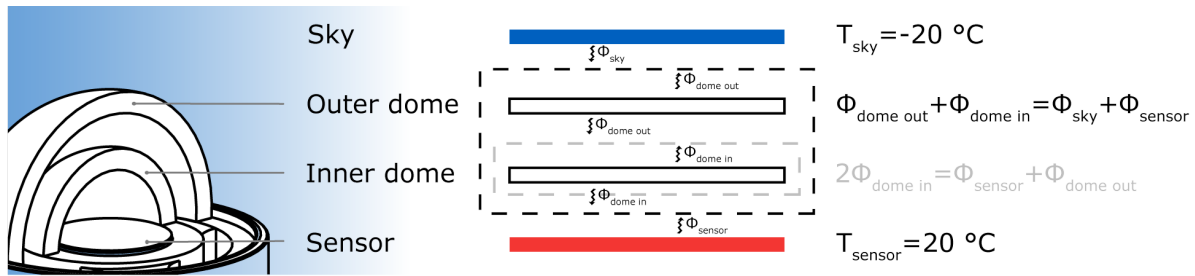

We now investigate the effect of thermal (infrared) exchange between the sensor and its surroundings. We will see that this causes a measurement offset that can be reduced by adding one or two domes. We use an oversimplified model where the sensor, domes and sky are infinite planes of perfect black bodies (emissivity $\epsilon = 1$).

Without a dome, there is direct thermal radiation exchange between the sensor (temperature T_{sensor}) and the sky (temperature T_{sky}). The sensor temperature is close to ambient temperature, for example $T_{\text{sensor}} = 20 \text{ }^\circ\text{C}$, while the sky temperature on clear days is much lower, for example $T_{\text{sky}} = -20 \text{ }^\circ\text{C}$. We use the Stefan-Boltzmann law to calculate the radiation fluxes from the sky and the sensor, and take their difference to arrive at a net sensor radiation of

$$\Phi_{\text{sensor,net}}^{(\text{no dome})} = \Phi_{\text{sky}} - \Phi_{\text{sensor}} = \sigma(T_{\text{sky}}^4 - T_{\text{sensor}}^4) = -185 \text{ W/m}^2.$$

Compared to typical solar irradiances of 1000 W/m^2 , this is an unacceptably large measurement offset.

We now extend our model sensor with a dome. For simplicity, we start with a dome that is thermally isolated except for heat transfer by radiation. Both sides of the dome have the same dome temperature T_{dome} , such that $\Phi_{\text{dome},\uparrow} = \Phi_{\text{dome},\downarrow} = \Phi_{\text{dome}}$. In steady state, the dome neither loses nor gains energy. The total radiation balance for the dome is then given by

$$2 \Phi_{\text{dome}}^{(\text{one dome})} = \Phi_{\text{sky}} + \Phi_{\text{sensor}},$$

resulting in a net sensor radiation of

$$\Phi_{\text{sensor,net}}^{(\text{one dome})} = \Phi_{\text{dome}}^{(\text{one dome})} - \Phi_{\text{sensor}} = \frac{1}{2}(\Phi_{\text{sky}} + \Phi_{\text{sensor}}) - \Phi_{\text{sensor}} = \frac{1}{2}(\Phi_{\text{sky}} - \Phi_{\text{sensor}}) = \frac{1}{2} \Phi_{\text{sensor,net}}^{(\text{no dome})}.$$

We immediately see that the thermal offset has been reduced by 50 %. Also, in practice the dome is thermally connected to the sensor body, further raising the dome temperature T_{dome} and the dome radiation flux Φ_{dome} . This leaves us with an even lower thermal offset.

Finally, we add a second dome. Now we have an inner dome (dome_{in}) and an outer dome (dome_{out}), with equilibrium radiation balances given by

$$\begin{aligned} 2 \Phi_{\text{dome}_{\text{in}}} &= \Phi_{\text{sensor}} + \Phi_{\text{dome}_{\text{out}}} && (\text{inner dome}), \\ \Phi_{\text{dome}_{\text{out}}} + \Phi_{\text{dome}_{\text{in}}} &= \Phi_{\text{sky}} + \Phi_{\text{sensor}} && (\text{combined inner \& outer dome system}). \end{aligned}$$

We combine these expressions to get

$$3 \Phi_{\text{dome}_{\text{in}}} = \Phi_{\text{sky}} + 2 \Phi_{\text{sensor}}.$$

Ultimately, we arrive at a net sensor radiation of

$$\Phi_{\text{sensor,net}}^{(\text{two domes})} = \Phi_{\text{dome}_{\text{in}}} - \Phi_{\text{sensor}} = \frac{1}{3} \Phi_{\text{sky}} + \frac{2}{3} \Phi_{\text{sensor}} - \Phi_{\text{sensor}} = \frac{1}{3}(\Phi_{\text{sky}} - \Phi_{\text{sensor}}) = \frac{1}{3} \Phi_{\text{sensor,net}}^{(\text{no dome})}.$$

Again we see a reduction in the thermal offset, this time by 66 %.

Of course, a more realistic model would contain hemispherical domes of finite size. However, the general result is still the same: the domes will adopt an intermediate temperature between the warm sensor and the cold sky.

Effectively, the sensor will 'see' the inner dome temperature instead of the cold sky and experience a reduced net exchange. The closer the inner dome temperature is to the sensor temperature, the better.

Table 1 list of 'zero offset a' specifications for Hukseflux pyranometers. ISO 9060 defines 'zero offset a' as the measurement offset caused by a thermal exchange of -200 W/m^2 between sensor and sky.

sensor	zero offset a as specified by Hukseflux
SR05	$< 15 \text{ W/m}^2$
SR15	$< 5 \text{ W/m}^2$
SR30	$< 5 \text{ W/m}^2$ in low power mode $< 2 \text{ W/m}^2$ in medium power mode $< 2 \text{ W/m}^2$ in standard operating mode

Conclusion

Laboratory tests to determine the longwave sensitivity of the three sensor models discussed in this note are shown in Figure 7. Indeed we see that

- a) a pyranometer with two domes has a lower thermal offset than a pyranometer with one dome.
- b) improved thermal uniformity by internal ventilation reduces thermal offsets even further.

To conclude, we have shown that a dome is necessary to make sure that the pyranometer sensor surface is only sensitive to solar radiation (shortwave) by blocking other sources of thermal exchange: most notably infrared (longwave) exchange with the cold sky and convective cooling by wind. Furthermore, we have seen that the infrared radiation shielding effect can be increased by installing a second dome.

References

1. ISO (1990) [ISO 9060:1990 Solar energy -- Specification and classification of instruments for measuring hemispherical solar and direct solar radiation](#)

See also

View our complete [product range of solar sensors](#)

Local support

Hukseflux has support available around the globe, with local representatives in:

- EU (Amsterdam region)
- USA (New York region)
- India (New Delhi region)
- China (Shanghai region)
- Japan (Tokyo region)

About Hukseflux

Hukseflux Thermal Sensors offers measurement solutions for the most challenging applications. We design and supply sensors as well as test & measuring systems, and offer related services such as engineering and consultancy. With our laboratory facilities, we provide testing services including material characterisation and calibration. Our main area of expertise is measurement of heat transfer and thermal quantities such as solar radiation, heat flux and thermal conductivity. Hukseflux is ISO 9001:2015 certified. Hukseflux sensors, systems and services are offered worldwide via our office in Delft, the Netherlands and local distributors.

Would you like more information?
 E-mail us at: info@hukseflux.com