

## TNS01

### THERMAL NEEDLE SET FOR THERMAL RESISTIVITY/ CONDUCTIVITY MEASUREMENT

The TNS01 Thermal Needle Set allows performing fast measurements of the thermal resistivity or conductivity of soils with optimal flexibility. The measurement complies with IEEE Standard 442-1981 as well as with ASTM D 5334-92 Standard. The system includes two different needles for use in the laboratory as well as on site. It is suggested to also consult the brochures of components FTN and MTN, as well as TPSYS, which is more accurate but has less robust needles.

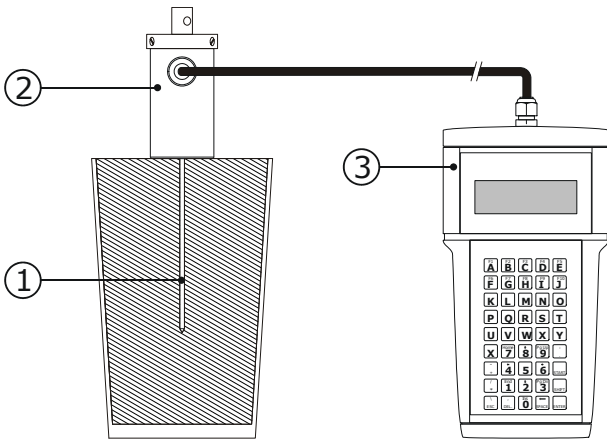
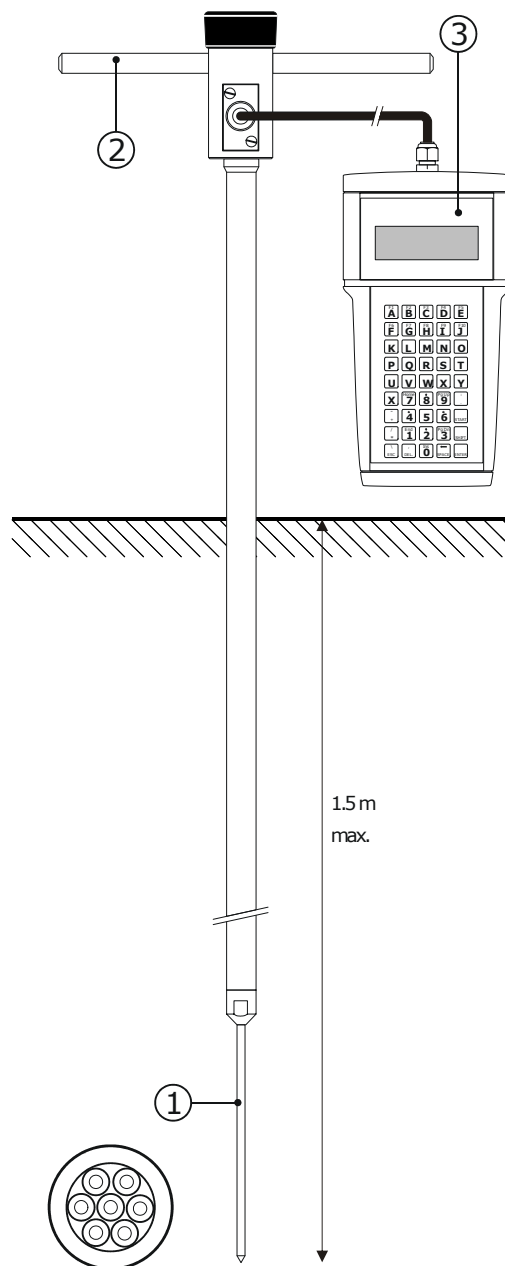

Figure 1 (above). TNS01 in operation. The Non-Steady-State Probe TP07 (1), mounted on the Insertion Tool IT02 (2), is inserted into the soil sample. The user performs control and read out of the experiment from the CRU01 (3), using its keyboard and LCD. The CRU01 contains a rechargeable battery pack for powering the TP07. The measurement result is immediately generated.

Figure 2 (right). TNS01 in operation. The Non-Steady-State Probe TP09 (1), mounted on the Lance LN01 (2), is inserted into the soil. This configuration is typically used for measurements around the typical depth of burial of high voltage cables, more than 1 meter depth in the field. The same CRU is used.



	Needle	Case	Tools	Added
FTN	TP09	TC01	LN01	CRU+ Access.
MTN	TP07	TC02	IT02	CRU+ Access.
TNS	TP09 & TP07	TC01	LN01 & IT02	CRU+ Access.

Table 1 TNS01 essentially consists of a combination of FTN and MTN components: the insertion tool IT02 and needle TP07 of MTN are added to FTN.

#### NEW!

For high accuracy calibration CRC Calibration Reference Cylinders are available.  
For insertion into hard soils GT Series Guiding tubes can be applied for needle type TP07.